

PERI Nájemní kritéria

MULTIPROP



Kontakt

PERI, spol. s r.o.
bednění lešení služby

Průmyslová 392
252 42 Jesenice u Prahy
tel.: 222 359 311
info@peri.cz
www.peri.cz

Obsah	Strana	Poslední změny	Datum Iniciály	Strana
Stropní stojky MULTIPROP	2	Nová verze	09/2015 I fw	
Rám MRK	8			
Příslušenství	12			
Vysvětlivky znaků	30			

PERI Nájemní kritéria

MULTIPROP



Stropní stojky MULTIPROP

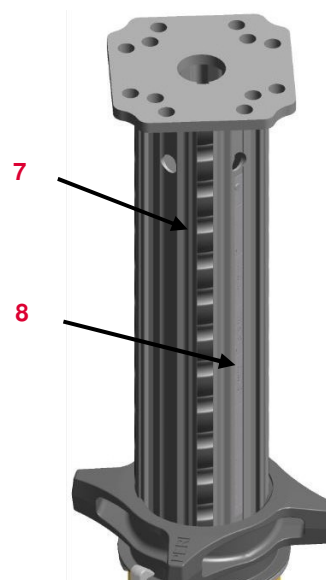
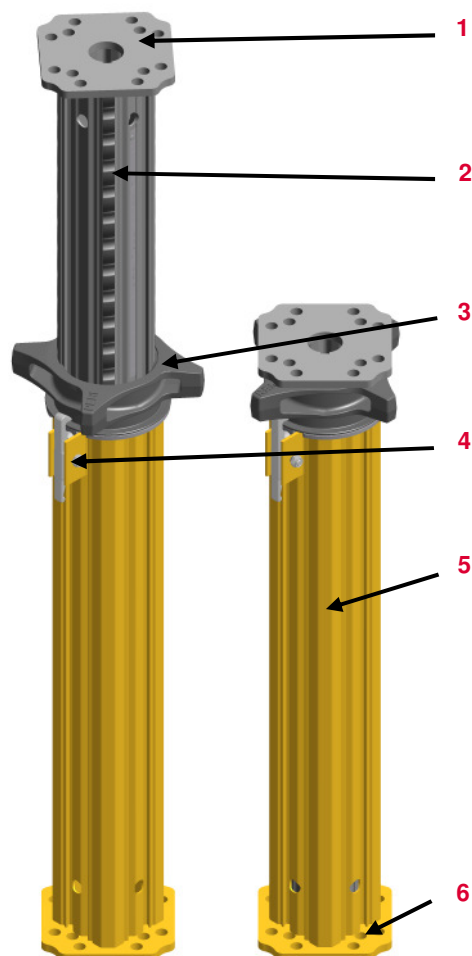







Č.	Popis	Číslo výrobku
1	Hlavová deska	
2	Vnitřní trubka	
3	Stavěcí matice	710273
4	Západka	710418
5	Vnější trubka	
6	Základní deska	
7	Závit	
8	Příruba	

Platný pro	Číslo výrobku
MULTIPROP MP 120	027288
MULTIPROP MP 250	027289
MULTIPROP MP 350	027290
MULTIPROP MP 480	027291
MULTIPROP MP 625	027305

PERI Nájemní kritéria

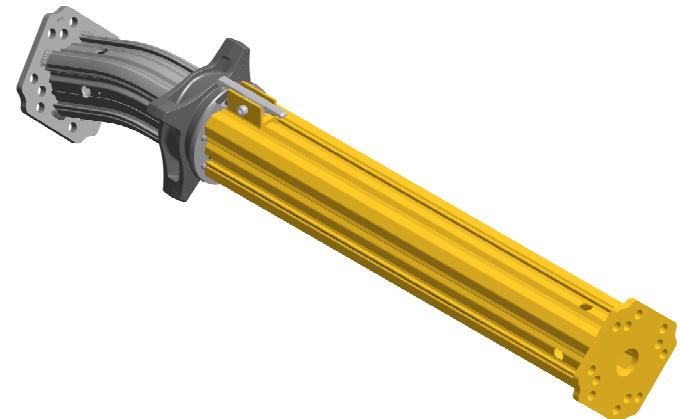













MULTIPROP



Stropní stojka	Popis	Instrukce	Fakturace	Typ		
	20.05.01 Promáčknutí/ prohnutí na vnější trubce					
	<ul style="list-style-type: none"> ■ pokud není trubka pohyblivá 			088381		
	<ul style="list-style-type: none"> ■ pokud je vnější trubka neopravitelná 		Výměna vnější trubky		Tabulka (str. 7)	
	20.05.02 Promáčknutí/prohnutí na vnitřní trubce		Výměna vnitřní trubky		Tabulka (str. 7)	
	<ul style="list-style-type: none"> ■ trubka není pohyblivá 		Výměna vnitřní trubky		Tabulka (str. 7)	
	<ul style="list-style-type: none"> ■ nebo > 2 mm v závitě 		Výměna vnitřní trubky		Tabulka (str. 7)	
	<ul style="list-style-type: none"> ■ nebo > 3 mm v přírubě 		Výměna vnitřní trubky		Tabulka (str. 7)	

PERI Nájemní kritéria MULTIPROP

















Stropní stojka	Popis	Instrukce	Fakturace	Typ	
	25.05.03 Značně znečištěná vnitřní trubka nebo měřidlo	<ul style="list-style-type: none"> ■ je možné očistit ■ není možné očistit 	  Výměna měřidla	  Tabulka (str. 7)	 
	25.05.04 Uvolněná brusná deska		 088380		
	25.05.05 Díra ve vnější trubce	<ul style="list-style-type: none"> ■ > Ø 5 mm 	 Výměna vnější trubky	 Tabulka (str. 7)	

PERI Nájemní kritéria

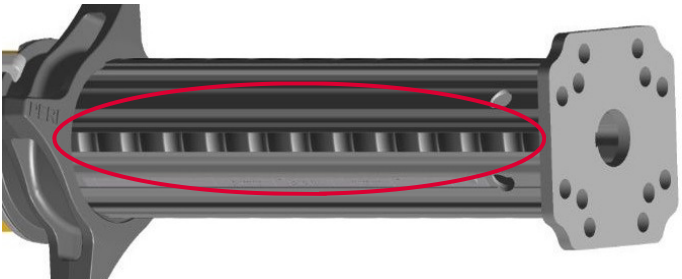
MULTIPROP



Stropní stojka	Popis	Instrukce	Fakturace	Typ
	<p>20.05.06 Ohnutá hlavová nebo základní deska</p> <ul style="list-style-type: none"> ■ ohnutí do 20 mm ■ ohnutí > 20 mm 	 	 	 
	<p>20.05.07 Prasklina ve sváru</p>			
	<p>20.05.08 Závits znečištěný betonem</p>			

PERI Nájemní kritéria

MULTIPROP



Stropní stojka	Popis	Instrukce	Fakturace	Typ
	20.05.09 Stavěcí matice			
	<ul style="list-style-type: none"> ■ odtržená část 		088378	
	<ul style="list-style-type: none"> ■ prasklina 			
	20.05.10 Západka poškozena, nebo je nefunkční			
	20.05.11 Kompletní zdeformování — Ohnutí vnitřní i vnější trubky			

PERI Nájemní kritéria

MULTIPROP



Výrobek	Výměna měřidla		Výměna vnější trubky		Výměna vnitřní trubky	
	Náhradní díl	Číslo servisního artiklu	Náhradní díl	Číslo servisního artiklu	Náhradní díl	Číslo servisního artiklu
MULTIPROP MP 120	710421	088370	702048	088401	702050	088400
MULTIPROP MP 250	710406	088374	702038	088403	702040	088402
MULTIPROP MP 350	710414	088375	702029	088405	702028	088404
MULTIPROP MP 480	710407	088376	702034	088407	720606	088406
MULTIPROP MP 625	720609	088373	720603	088409	720606	088408

PERI Nájemní kritéria

MULTIPROP



Rám MRK	Č.	Popis	Číslo výrobku
---------	----	-------	---------------

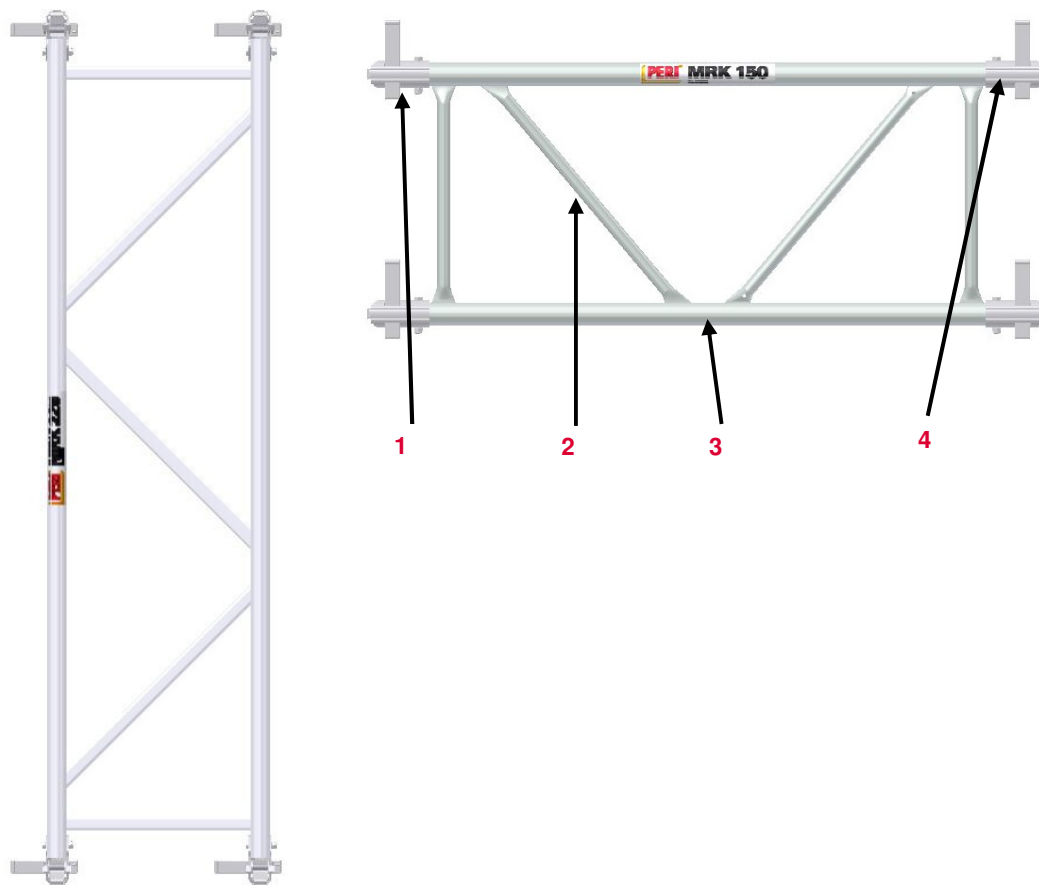









1	Úchyt C	105881
2	Výztuha	
3	Rám	
4	Úchyt D	105874

Platné pro	Číslo výrobku
Rám MRK 62,5	028390
Rám MRK 75	028400
Rám MRK 90	028330
Rám MRK 120	028340
Rám MRK 137,5	028380
Rám MRK 150	028350
Rám MRK 201,5	028460
Rám MRK 225	028360
Rám MRK 230	028470
Rám MRK 237	028480
Rám MRK 266	028490
Rám MRK 296	028370

PERI Nájemní kritéria

MULTIPROP



MRK	Popis	Instrukce	Fakturace	Typ
	20.05.12 Nefunkční úchyt	 105881 (Úchyt C) 105874 (Úchyt D)		
	20.05.13 Ohnutá uchytka v horní nebo dolní čelisti	 105881 (Úchyt C) 105874 (Úchyt D)	 088379	

PERI Nájemní kritéria MULTIPROP



MRK	Popis	Instrukce	Fakturace	Typ
-----	-------	-----------	-----------	-----



20.05.14 Ohnutý rám

■ ≤ povolená deformace (l/500)



■ > povolená deformace











Výrobek	Pov. ohnutí
MRK 62,5	3,0 mm
MRK 75	3,0 mm
MRK 90	3,0 mm
MRK 120	3,0 mm
MRK 137,5	3,0 mm
MRK 150	3,0 mm
MRK 201,5	4,0 mm
MRK 225	4,5 mm
MRK 230	4,5 mm
MRK 237	5,0 mm
MRK 266	5,0 mm
MRK 296	6,0 mm

PERI Nájemní kritéria

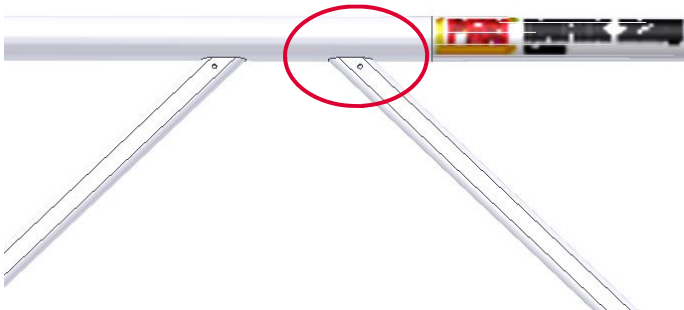
MULTIPROP



MRK	Popis	Instrukce	Fakturace	Typ
	20.05.15 Klín rezavý/opotřebovaný ■ nefunkční	 105881 (Úchyt C) 105874 (Úchyt D)		
	20.05.16 Prasklina ve sváru	 		

PERI Nájemní kritéria MULTIPROP

















Patka MP 50 (027310)	Popis	Instrukce	Fakturace	Typ
	20.05.17 Důlky na trubce			
	<ul style="list-style-type: none"> ■ ≤ 6 mm hloubka $\leq \varnothing 60$ mm 			
	<ul style="list-style-type: none"> ■ > 6 mm hloubka 			
<ul style="list-style-type: none"> ■ $> \varnothing 60$ mm 				
	20.05.18 Ohnutá hlava nebo patka			
	<ul style="list-style-type: none"> ■ ≤ 15 mm 		088244	
<ul style="list-style-type: none"> ■ > 15 mm 				

PERI Nájemní kritéria

MULTIPROP











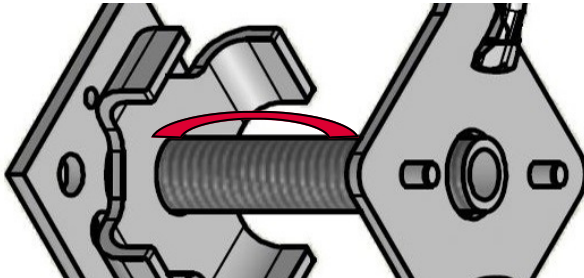



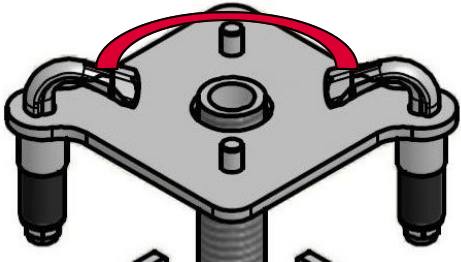

Patka MP 50 (027310)	Popis	Instrukce	Fakturace	Typ	
	<p>20.05.19 Pružná trubka vadná, chybí</p> <ul style="list-style-type: none"> ■ pružná trubka 1. verze (černá) ■ pružná trubka 2. verze (oranžová) 	 	 	088367	 
	<p>20.05.20 Napínací chapadlo (upínka) poškozené, chybí</p>			088368	
	<p>20.05.21 Napínací chapadlo (upínka) neutažená</p>				
	<ul style="list-style-type: none"> ■ matici utáhněte tak, aby ručně bylo možné upínkou pohnout jen stěží 				

PERI Nájemní kritéria

MULTIPROP

















Kalotová patka MKF (027296)	Popis	Instrukce	Fakturace	Typ		
	20.05.22 Ohnuté vřeteno					
	20.05.23 Zdeformovaná hlavová nebo základní deska			088244		
	20.05.23 Otočné křídlo ohnuté	<ul style="list-style-type: none"> ■ bez viditelných trhlin na otočném křídle ■ s viditelnými trhlinami na otočném 			088244	
						

PERI Nájemní kritéria

MULTIPROP



Kalotová patka MKF (027296)	Popis	Instrukce	Fakturace	Typ
	<p>20.05.25 Pružná trubka vadná, chybí</p> <ul style="list-style-type: none"> ■ pružná trubka 1. verze (černá) ■ pružná trubka 2. verze (oranžová) 	 	 	 
	<p>20.05.26 Napínací chapadlo (upínka) poškozené, chybí</p>			
	<p>20.05.27 Napínací chapadlo (upínka) neutažená</p> <ul style="list-style-type: none"> ■ matici utáhněte tak, aby ručně bylo možné upínkou pohnout jen stěží 			

PERI Nájemní kritéria

MULTIPROP

















Kalotová křížová hlava MKK (027297)	Popis	Instrukce	Fakturace	Typ
	20.05.28 Ohnuté vřeteno			
	20.05.29 Zdeformovaná hlavová nebo základní deska			
	<p>20.05.30 Otočné křídlo ohnuté</p> <ul style="list-style-type: none"> ■ bez viditelných trhlin na otočném křídle ■ s trhlinami na otočném křídle 	 	088244 088244	
	<p>20.05.31 Ohnutá vidlice</p> <ul style="list-style-type: none"> ■ bez praskliny ve sváru ■ s prasklinou ve sváru 	 	088395 088394	

PERI Nájemní kritéria

MULTIPROP



Kalotová křížová hlava MKK (027297)	Popis	Instrukce	Fakturace	Typ
	<p>20.05.32 Pružná trubka vadná, chybí</p> <ul style="list-style-type: none"> ■ pružná trubka 1. verze (černá) ■ pružná trubka 2. verze (oranžová) 	 	  088367	 
	<p>20.05.33 Napínací chapadlo (upínka) poškozené, chybí</p>			
	<p>20.05.34 Napínací chapadlo (upínka) neutažená</p> <ul style="list-style-type: none"> ■ ■ matice utáhněte tak, aby ručně bylo možné upínkou pohnout jen stěží 			

PERI Nájemní kritéria

MULTIPROP



Univerzální trojnožka (028000)	Č.	Popis	Číslo výrobku
--------------------------------	----	-------	---------------

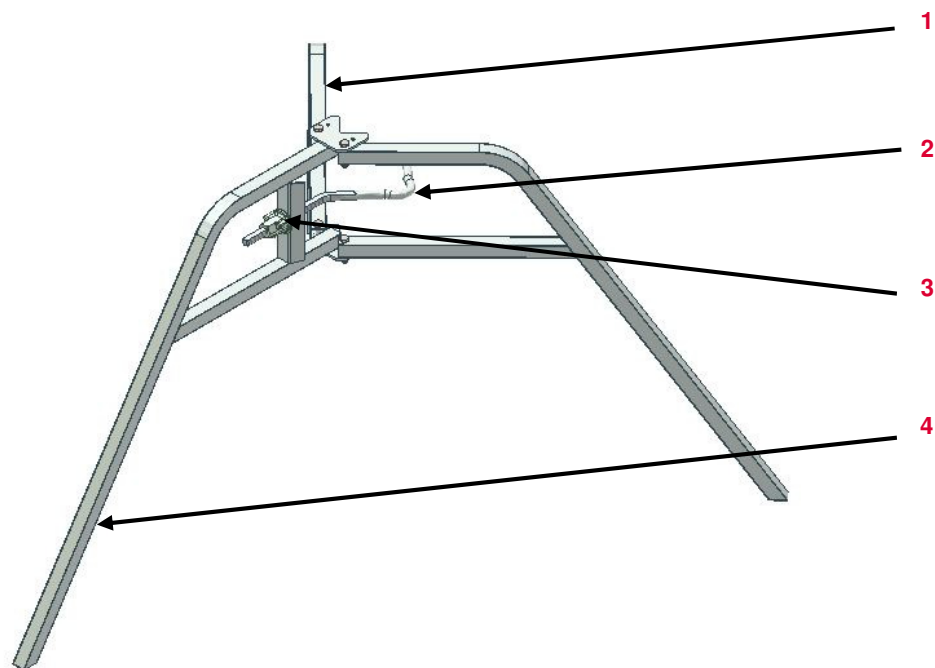









1	Otočný výložník	715643
2	Upínací držadlo	710161
3	Palcová matice	030130
4	Pevný výložník	715642

PERI Nájemní kritéria

MULTIPROP









Univerzální trojnožka	Popis	Instrukce	Fakturace	Typ
	20.05.35 Ohnutý otočný výložník	<ul style="list-style-type: none"> je možné narovnat 	  088244	
	<ul style="list-style-type: none"> není možné narovnaní 	 715643		
	20.05.36 Ohnutý pevný výložník	<ul style="list-style-type: none"> je možné narovnat 	 	
	<ul style="list-style-type: none"> není možné narovnaní 	 		

PERI Nájemní kritéria

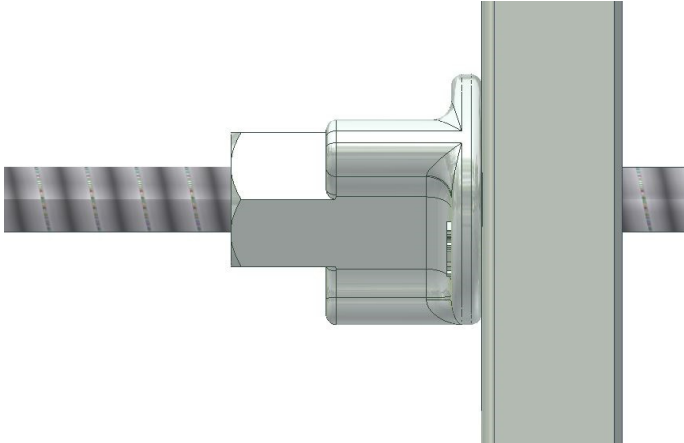
MULTIPROP



Univerzální trojnožka	Popis	Instrukce	Fakturace	Typ
	20.05.37 Ohnuté upínací držadlo ■ > 100°			
	20.05.38 Poškozená palcová matice	 030130 (palcová matice) 767043	 088429	

PERI Nájemní kritéria

MULTIPROP



Lešenářská spojka MG-A/C	Č.	Popis	Číslo výrobku
--------------------------	----	-------	---------------

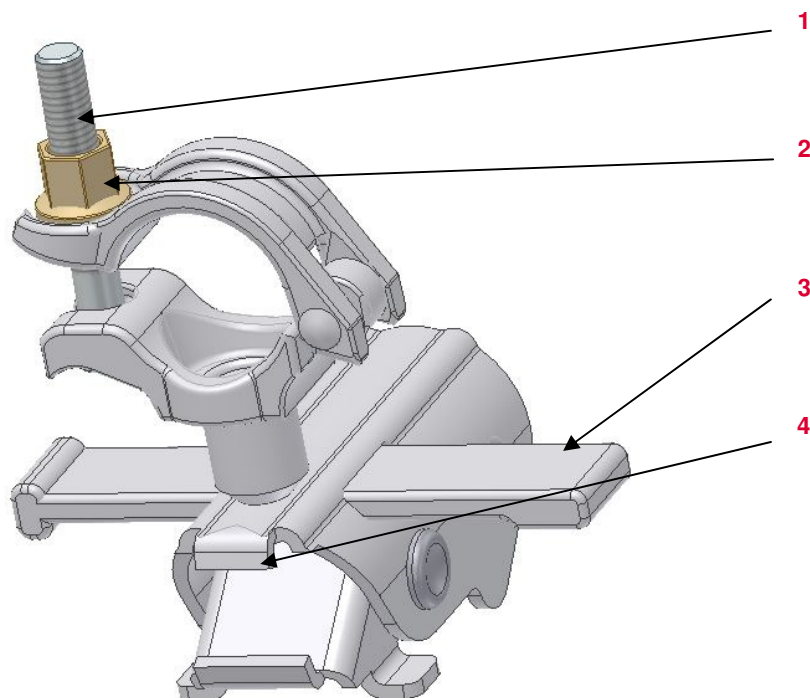











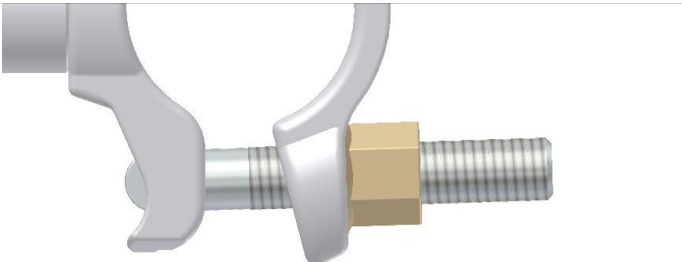

1	Šroub s klad. hlavou	710702
2	Matice	710340
3	Klín	
4	Úchyt	

Platné pro	Číslo výrobku
Lešenářská spojka MG-A/C	027298
Lešenářská spojka MG-B/D	027299

PERI Nájemní kritéria

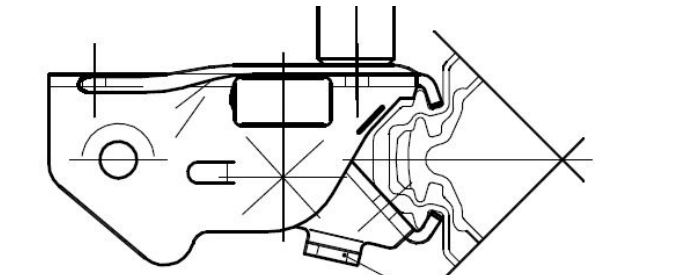
MULTIPROP









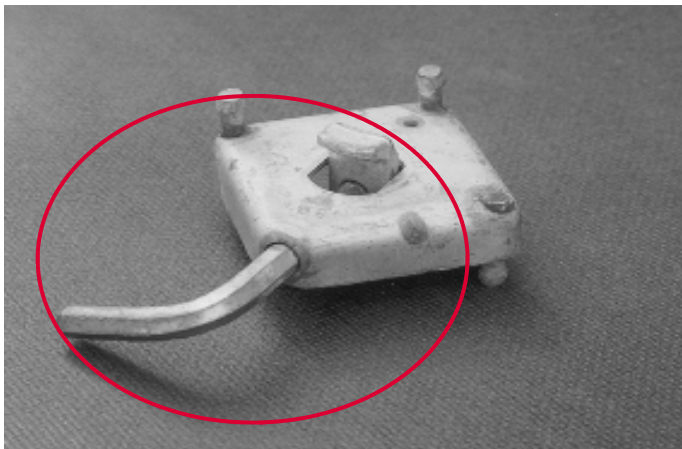

Lešenářská spojka MG-A/C	Popis	Instrukce	Fakturace	Typ
	<p>20.05.39 Šroub s klad. hlavou poškozený, chybějící</p>	 710702 (Šroub s klad. hlavou) 710340 (Matice)	 088388 088360	
	<p>20.05.40 Nefunkční klín</p>	 		
	<p>20.05.41 Nefunkční připojení ke stojce MULTIPROP</p>	 		

PERI Nájemní kritéria

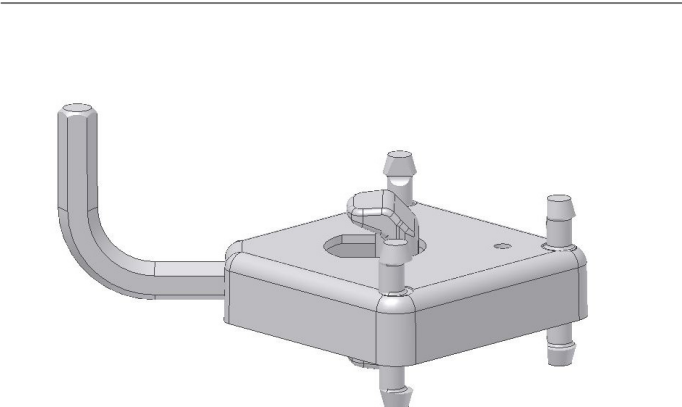
MULTIPROP



Úchyt MPV-2 (027301)	Popis	Instrukce	Fakturace	Typ
	20.05.42 Chybí aretační čep nebo napínák	 		
	20.05.43 Deformovaný úchyt	 		

PERI Nájemní kritéria

MULTIPROP





MULTIPROP Hlava (027302)	Popis	Instrukce	Fakturace	Typ
	20.05.44 Ohnutá vzpěra			
	20.05.45 Ohnutý třmen ■ > 10 mm			

PERI Nájemní kritéria

MULTIPROP



Spona MPB (111000)	Popis	Instrukce	Fakturace	Typ
	20.05.46 Ohnutý závit			
	20.05.47 Plech poškozený, deformovaný	 		

PERI Nájemní kritéria

MULTIPROP



Hliníkový nosník MPB 24

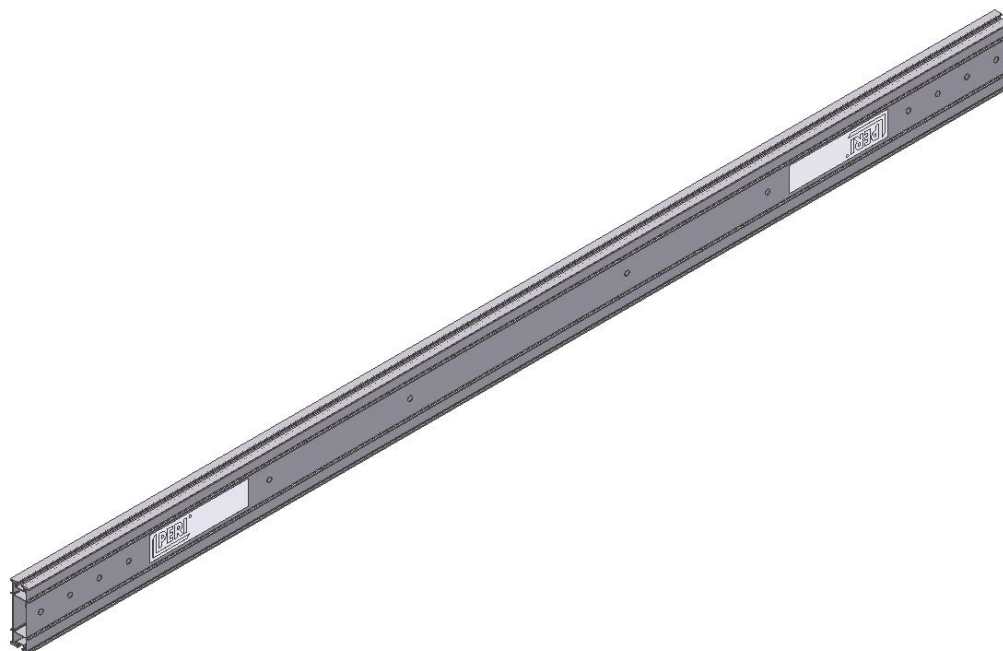

Č.	Popis	Číslo výrobku
----	-------	---------------

Platné pro	Číslo výrobku
Nosník MPB 24, L= 3,00 m	079300
Nosník MPB 24, L= 3,60 m	079360
Nosník MPB 24, L= 4,20 m	079420
Nosník MPB 24, L= 4,80 m	079480
Nosník MPB 24, L= 5,40 m	079540
Nosník MPB 24, L= 6,00 m	079600

PERI Nájemní kritéria

MULTIPROP



Hliníkový nosník MPB 24	Popis	Instrukce	Fakturace	Typ
-------------------------	-------	-----------	-----------	-----



20.05.48 Díry

■ ≤ Ø 5 mm



■ > Ø 5 mm



20.05.49 Zkrácený nosník

■ je povoleno v kombinaci se správným vrtáním děr

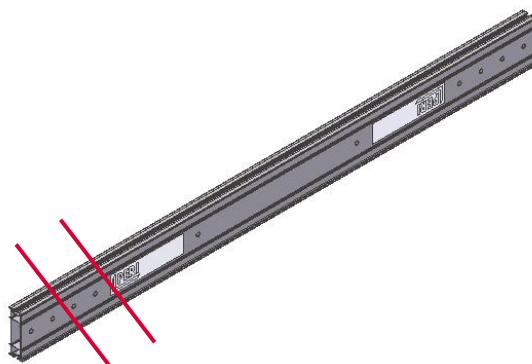

PERI Nájemní kritéria MULTIPROP



Hliníkový nosník MPB 24	Popis	Instrukce	Fakturace	Typ
-------------------------	-------	-----------	-----------	-----

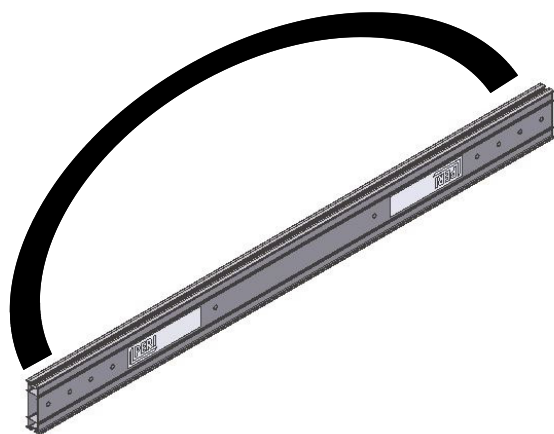

20.05.50 Nosník ohnutý

■ ≤ povolené ohnutí



■ > povolené ohnutí



Výrobek	Pov. ohnutí
MPB 24, L= 3,00 m	6,0 mm
MPB 24, L= 3,60 m	7,0 mm
MPB 24, L= 4,20 m	9,0 mm
MPB 24, L= 4,80 m	9,5 mm
MPB 24, L= 5,40 m	11,0 mm
MPB 24, L= 6,00 m	12,0 mm

PERI Nájemní kritéria

MULTIPROP



Spojka MPB (107348)	Popis	Instrukce	Fakturace	Typ
	20.05.51 Ohnutá spojka			

PERI Nájemní kritéria

Vysvětlivky znaků



Znak	Význam	Znak	Význam	Znak	Význam
	Není v pořádku – materiál je poškozený		Fakturuje se zákazníkovi		Optické poškození
	OK – materiál zůstává v nájemním skladu		Nefakturuje se zákazníkovi		Funkční poškození
	Poškozený materiál – není dovoleno vydávat materiál z bezpečnostních důvodů		Zkrácení prvku		Funkční poškození — není dovoleno vydávat materiál z bezpečnostních důvodů
	Oprava dle instrukcí		Označení prvku barvou		Statické poškození — není dovoleno vydávat materiál z bezpečnostních důvodů
	Oprava za studena — poté kontrola svárů a sousedních dílů		Výměna poškozeného dílu		
	Oprava po výpočtu hospodárnosti		Doplnění chybějícího dílu		
	Očištění materiálu				