

PERI Nájemní kritéria

ALPHAKIT

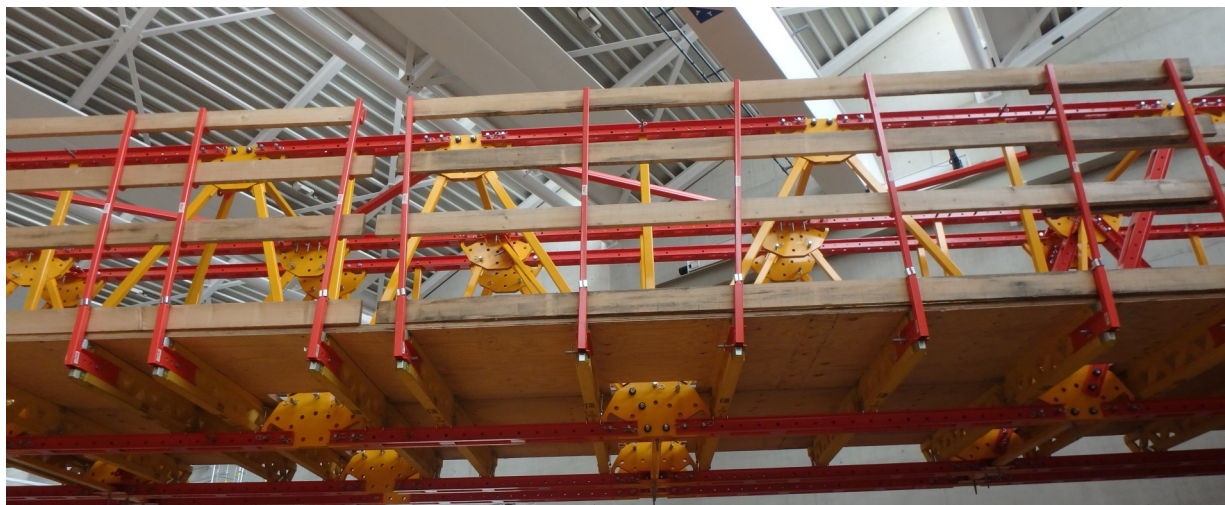

Kontakt

PERI, spol. s r.o.
bednění lešení služby
Prumyslová 392
252 42 Jesenice u Prahy
tel.: 222 359 311
info@peri.cz
www.peri.cz

Obsah	Strana	Provedené změny	Datum Kdo	Strana
Diagonála	2	Nová verze	08/2016 fw	
Horizontální vzpěry	6	Přidána konzola pro nosník	08/2019 fw	9
Ocelová závora	7	Přidáno Vřeteno ATS 360-550	10/2019 fw	29
Nosník	8	Přidána podpěrná diagonála - 2 ATG	04/2021 fw	18
Konzola pro nosník	9	Přidány nové výrobky	03/2022 fw	31-36
Montážní prvky	10			
Vysvětlivky	37			

PERI Nájemní kritéria ALPHAKIT



Diagonála	Číslo	Název	Číslo výrobku
-----------	-------	-------	---------------

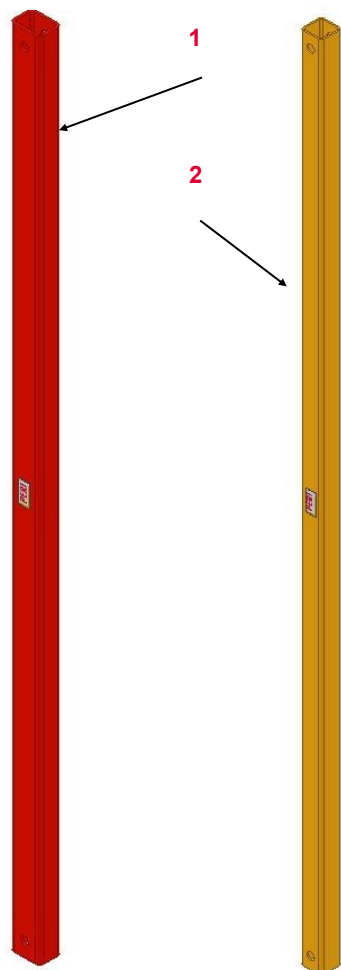



















1 Diagonála-6

2 Diagonála-4

Platné pro:

Diagonála-6 150/212 Alpha	130090
Diagonála-6 150/262 Alpha	130079
Diagonála-6 150/162 Alpha	130071
Diagonála-6 100/262 Alpha	130063
Diagonála-6 100/212 Alpha	130061
Diagonála-6 100/162 Alpha	130059
Diagonála-4 150/136 Alpha	130055
Diagonála-4 150/162 ATS	130053
Diagonála-4 150/186 Alpha	130051
Diagonála-4 150/262 Alpha	130049
Diagonála-4 150/212 ATS	130047

Diagonála	Popis	Instrukce	Fakturace	Typ
	04.16.01 Ohnutá diagonála			
	■ ≤ povolené ohnutí (l/500)			
	■ > povolené ohnutí (l/500)			
	Povolené ohnutí			
	Diagonála-6 150/212 Alpha	5 mm		
	Diagonála-6 150/262 Alpha	6 mm		
	Diagonála-6 150/162 Alpha	4 mm		
	Diagonála-6 100/262 Alpha	6 mm		
	Diagonála-6 100/212 Alpha	5 mm		
	Diagonála-6 100/162 Alpha	4 mm		
Diagonála-4 150/136 Alpha	4 mm			
Diagonála-4 150/162 ATS	4 mm			
Diagonála-4 150/186 Alpha	5 mm			
Diagonála-4 150/262 Alpha	6 mm			
Diagonála-4 150/212 ATS	5 mm			

Diagonála	Popis	Instrukce	Fakturace	Typ
	04.16.02 Promáčknutý profil	<ul style="list-style-type: none"> ■ ≤ 5 mm hloubky Bez poškození hrany 		
	<ul style="list-style-type: none"> ■ > 5 mm hloubky 	 		
	<ul style="list-style-type: none"> ■ Poškození hran 	 		
	04.16.03 Deformovaný koncový profil	<ul style="list-style-type: none"> ■ Je-li možno 		
	<ul style="list-style-type: none"> ■ Nelze opravit 	 		

Diagonální příhrada 212; 262 (130098; 130122)	Popis	Instrukce	Fakturace	Typ
---	-------	-----------	-----------	-----



04.16.04 Prohnutí prvku

- > 5 mm



04.16.05 Ohnutá spojka

- Je-li možno



088244



- Nelze opravit



- Prasklina ve sváru



Horizontální vzpěra



Platné pro:

Horizontální vzpěra 37.5 Alpha	130085
Horizontální vzpěra 50 Alpha	130067
Horizontální vzpěra 75 Alpha	130083
Horizontální vzpěra 100 Alpha	130069
Horizontální vzpěra 150 Alpha	130065

Poškození

Popis

Instrukce

Fakturace

Typ

04.16.06 Ohnutý profil



- > 5 mm



04.16.07 Deformovaný koncový profil



- Je-li možno
- Nelze opravit



088244



Ocelová závora

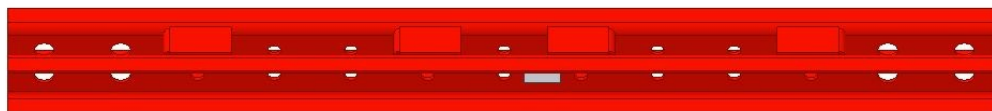

Platné pro:

Ocelová závora 162 Alpha	129877
Ocelová závora 212 Alpha	129874
Ocelová závora 262 Alpha	129871

Poškození

Popis

Instrukce

Fakturace

Typ

04.16.08 Ohnutý koncový profil

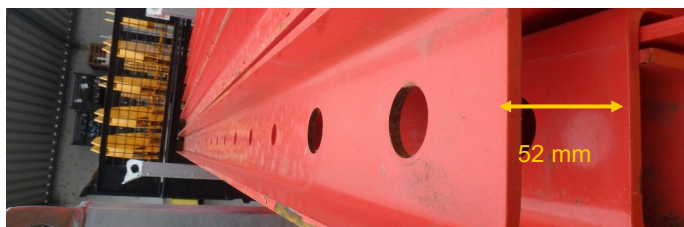

- Je-li možno
- Nelze opravit



088244



04.16.09 Ohnutý prvek



- > 5 mm



Nosník



Platné pro:

Nosník 300 Alpha	130042
Nosník 500 Alpha	130039
Nosník 1000 Alpha	130036

Poškození

Popis

Instrukce

Fakturace

Typ

04.16.10 Nosník

- > 15 mm (L/500)

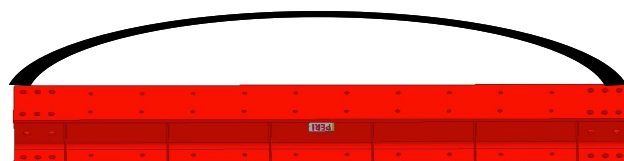

Konzola pro nosník (132622)	Popis	Instrukce	Fakturace	Typ
-----------------------------	-------	-----------	-----------	-----

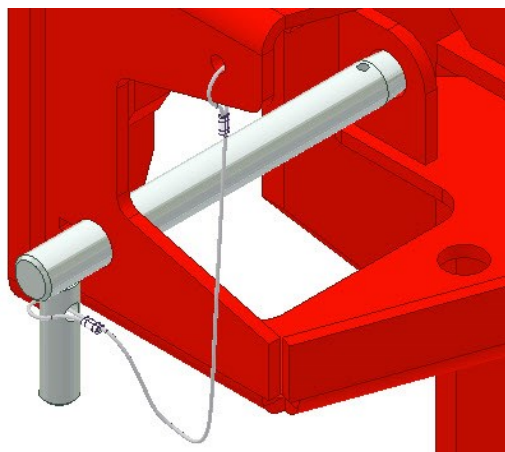

Čep | Lanko 2,0MM chybí



113247 (Čep)
127303 (Lanko 2,0MM)

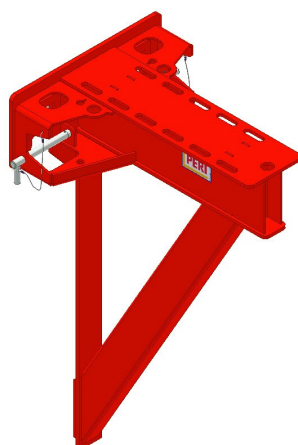











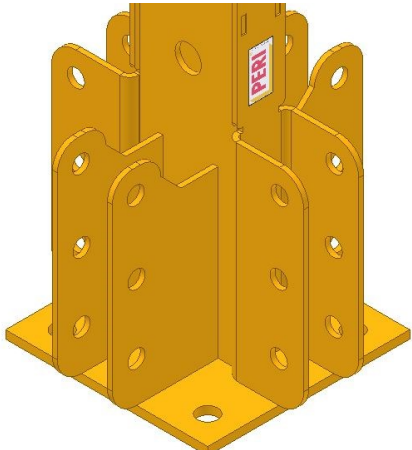





Ohnutá konzola

■ Je-li možno

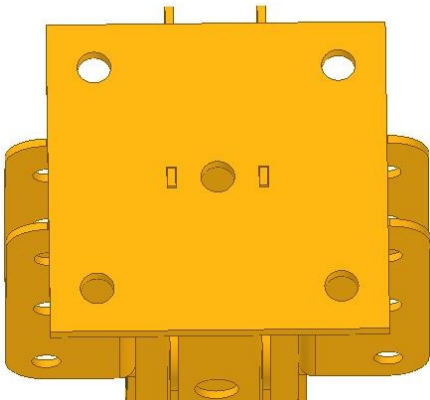

■ Nelze opravit



Základní rám ATS (130150)	Popis	Instrukce	Fakturace	Typ
	04.16.11 Ohnuté spojovací prvky			
	<ul style="list-style-type: none"> ■ Je-li možno 		 088244	
	<ul style="list-style-type: none"> ■ Nelze opravit 	 		
<ul style="list-style-type: none"> ■ Prasklina ve sváru 	 			
	04.16.12 Ohnutá spodní patka			
			 088244	

Ztužující konektor ATG; 75 (130124;130081)	Popis	Instrukce	Fakturace	Typ
--	-------	-----------	-----------	-----

04.16.13 ohnutí

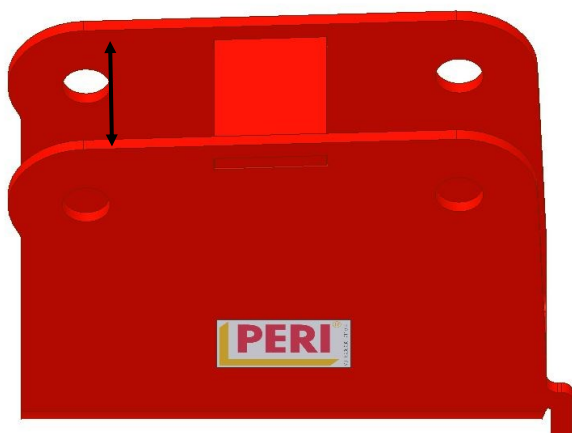

088244



04.16.14 Ohnutá zarážka

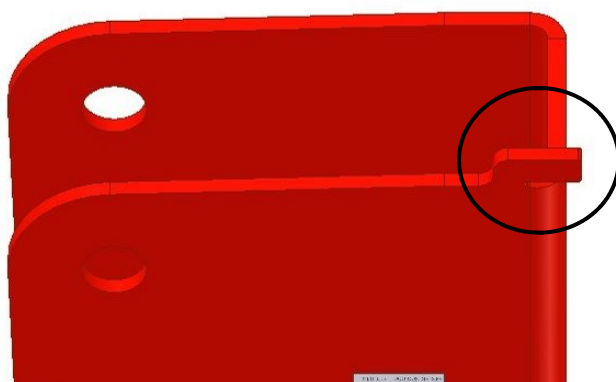

088244



PERI Nájemní kritéria

ALPHAKIT



Ztužující konzola ATG (130119)	Popis	Instrukce	Fakturace	Typ
--------------------------------	-------	-----------	-----------	-----



04.16.15 Ohnuté spojovací plochy



088244



Styčnicková opěra (130115)	Popis	Instrukce	Fakturace	Typ
----------------------------	-------	-----------	-----------	-----



04.16.16 Ohnutí držáků



088244

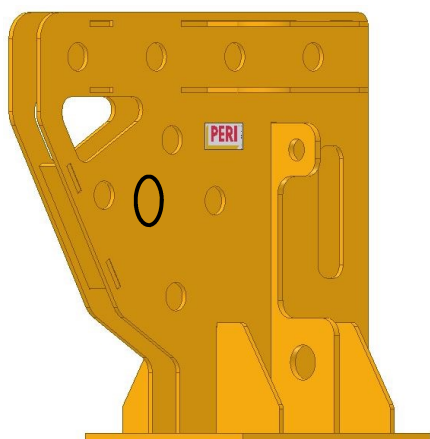

04.16.17 Promáčknutý profil

■ > 5 mm hloubky



PERI Nájemní kritéria

ALPHAKIT



Vertikální spojka ATS (130108)	Popis	Instrukce	Fakturace	Typ
--------------------------------	-------	-----------	-----------	-----



04.16.18 Ohnuté spojovací plochy



088244











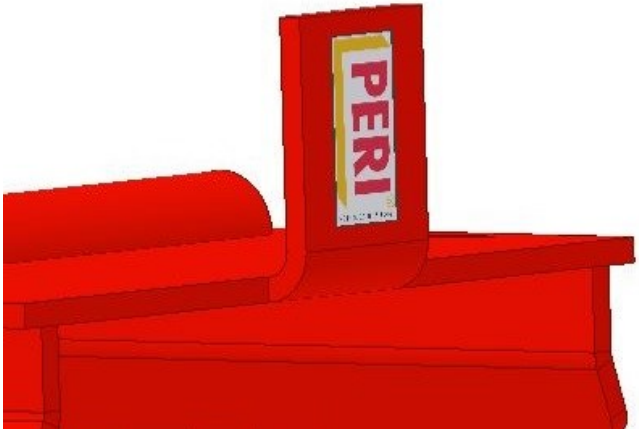





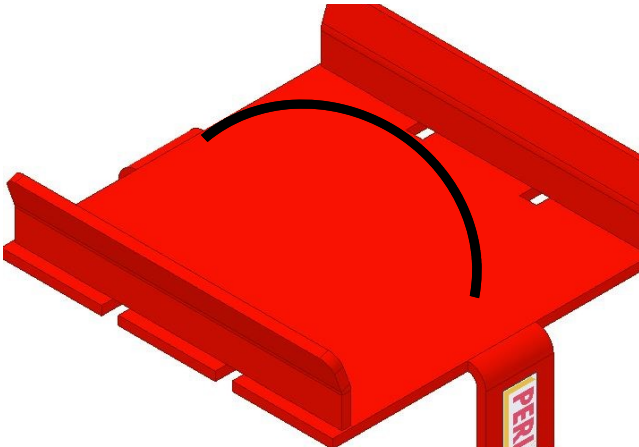

04.16.19. Ohnutý koncový profil

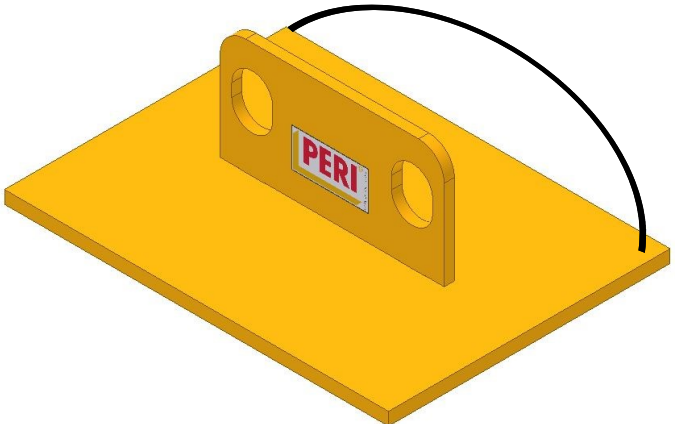

088244



Podpěrná hlava ATG (130103)	Popis	Instrukce	Fakturace	Typ
	04.16.20 Ohnutá deska	<ul style="list-style-type: none"> ■ Je-li možno 	 088244	
	<ul style="list-style-type: none"> ■ Nelze opravit 			
	04.16.21 Ohnutá základní deska	<ul style="list-style-type: none"> ■ > 5 mm 		

Podpurný adaptér ATG (130094)	Popis	Instrukce	Fakturace	Typ
	<p>04.16.22 Ohnutá deska</p> <ul style="list-style-type: none"> ■ > 5 mm 			
	<p>04.16.23 Ohnutá podpurná deska</p>		 088244	

PERI Nájemní kritéria

ALPHAKIT



Podpěrná diagonála ATG (130088)	Popis	Instrukce	Fakturace	Typ
---------------------------------	-------	-----------	-----------	-----

04.16.24 Ohnutá trubka



■ > 5 mm



04.16.25 Ohnutý držák



088244











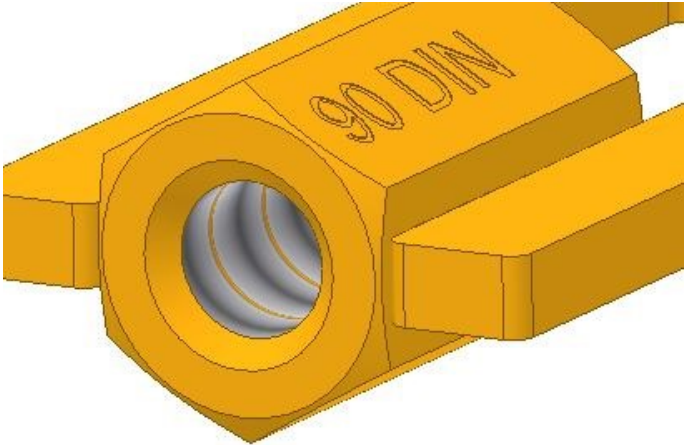

PERI Nájemní kritéria

ALPHAKIT

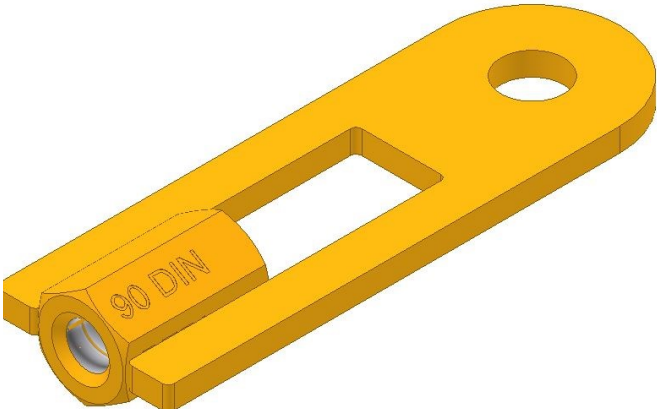

Podpěrná diagonála ATG– 2 (137201)	Popis	Instrukce	Fakturace	Typ
	Ohnuté úchyty			
	<ul style="list-style-type: none"> ■ Lze narovnat 			
	<ul style="list-style-type: none"> ■ Nelze narovnat 			
<ul style="list-style-type: none"> ■ Prasklina ve sváru 				

H- Tažná příložka DW 15 (130032)	Popis	Instrukce	Fakturace	Typ	
	04.16.26 Závít				
	<ul style="list-style-type: none"> ■ Znečištěný ■ Nefunkční závít 		Zbroušení závitu		
	04.16.27 Ohnutí			088244	

PERI Nájemní kritéria

ALPHAKIT



H- tažná spojka ATG (130029)	Číslo	Název	Číslo výrobku
------------------------------	-------	-------	---------------

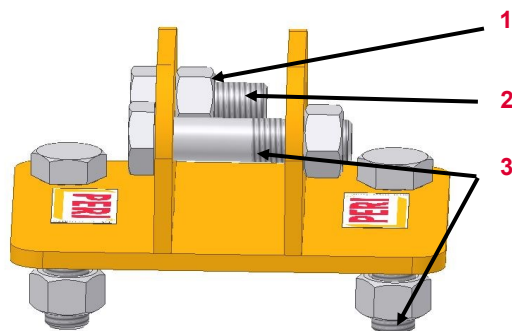

1	Matice M 20	710334
2	Šroub M 20x 50	780357
3	Šroub M 20x 70	721912

Poškození	Popis	Instrukce	Fakturace	Typ
-----------	-------	-----------	-----------	-----

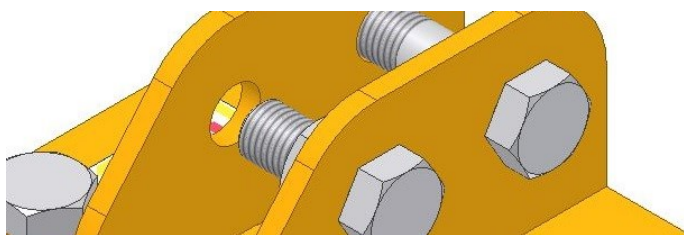

04.16.28 Ohnutí



088244

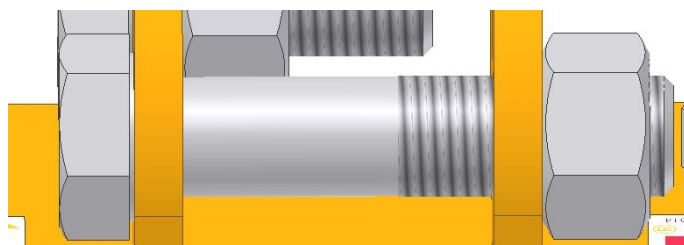

04.16.29 Šroub | Matice

- Chybí
- Poškozeno



088024

088024



PERI Nájemní kritéria

ALPHAKIT



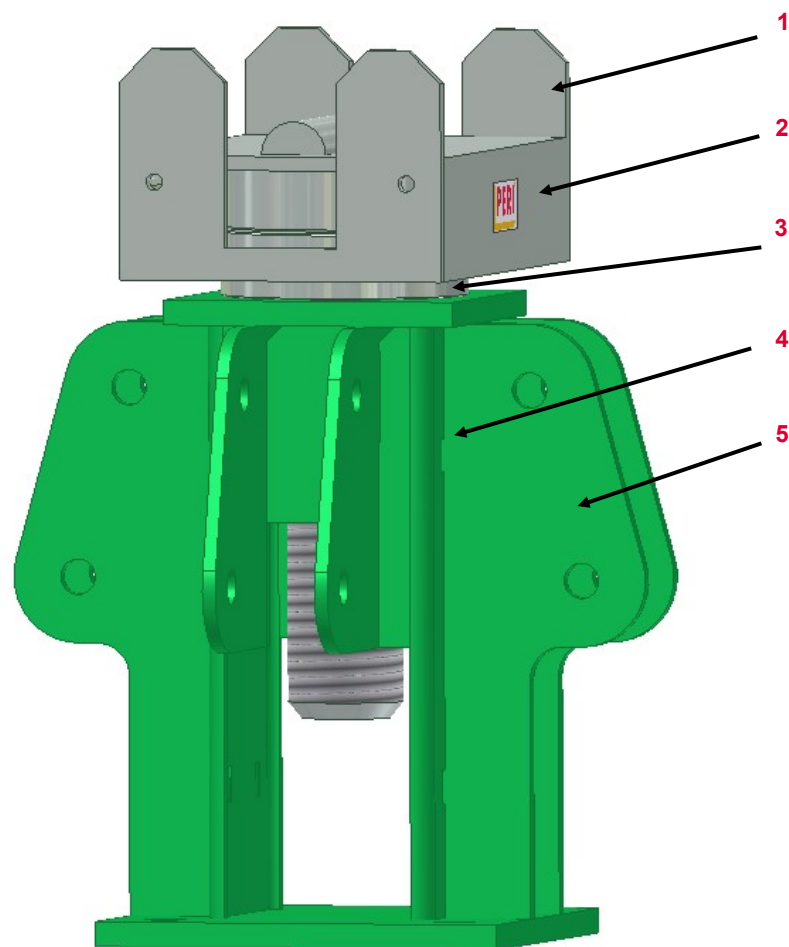

Hlava s vřetenem ATS (130144)

Číslo	Název	Číslo výrobku
-------	-------	---------------

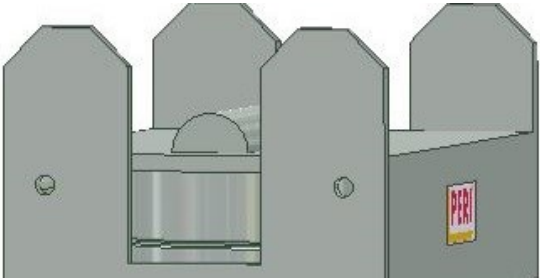

1	Boční profil	
2	Vřeteno	130134
3	Matice TR 70	130128
4	Hlava vřetene	
5	Podpěrné spojky	

Hlava vřetene ATS	Popis	Instrukce	Fakturace	Typ	
	04.16.30 ohnutý boční profil				
	<ul style="list-style-type: none"> ■ Je-li možno 	088244			
	04.16.31 Ohnuté spojovací podpěry				
	<ul style="list-style-type: none"> ■ Nelze opravit 	130134 (Vřeteno)	088244		
	04.16.31 Nepoužitelné vřeteno				
130134 (Vřeteno)					

Žebříkové připojení 60/60 ATS (130077)

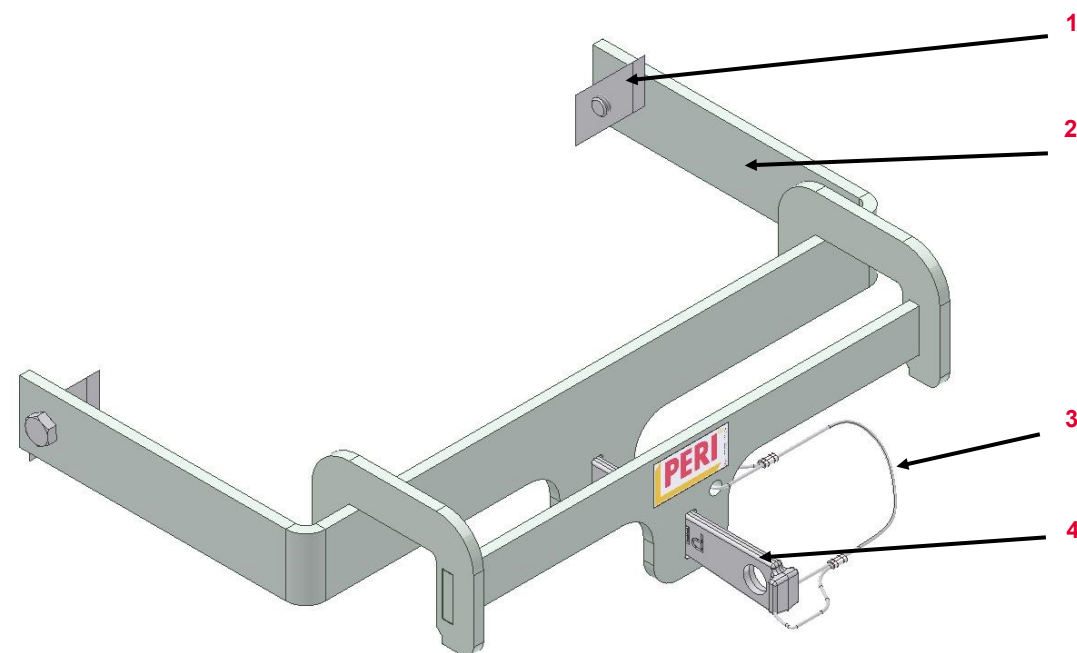

Číslo	Název	Číslo výrobku
-------	-------	---------------

1	Svěrací destička 25x10x90	701763
---	---------------------------	--------

2	Rám	
---	-----	--











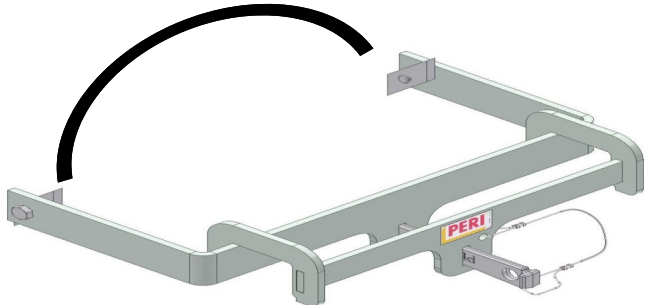

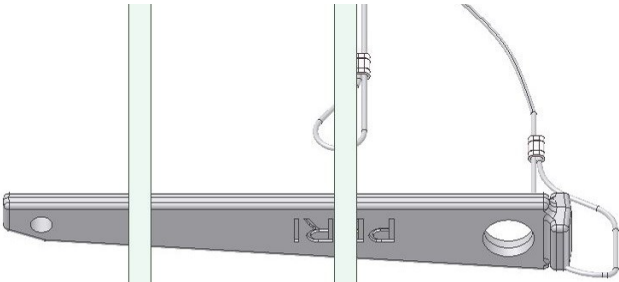

3	Lanko 2,0MM	127303
---	-------------	--------

4	Klín K	024250
---	--------	--------

PERI Nájemní kritéria

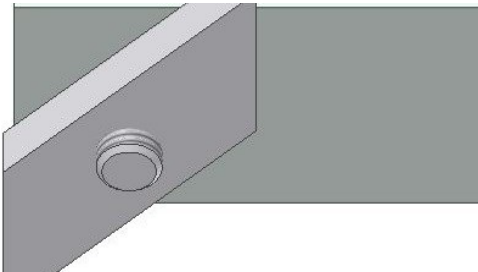
ALPHAKIT



Žebříkové připojení (130077)	Popis	Instrukce	Fakturace	Typ
	04.16.32 Ohnuté			
	<ul style="list-style-type: none"> ■ Je-li možno 		088244	
	<ul style="list-style-type: none"> ■ Nelze opravit 			
	04.16.33 Chybějící klín			
		024250 (Klín K) 127303 (Lanko 2,0MM) 127302 (Kroužek)		
	04.16.34 Svěrací destička 25x10x90 poškozená			
		701763		

PERI Nájemní kritéria







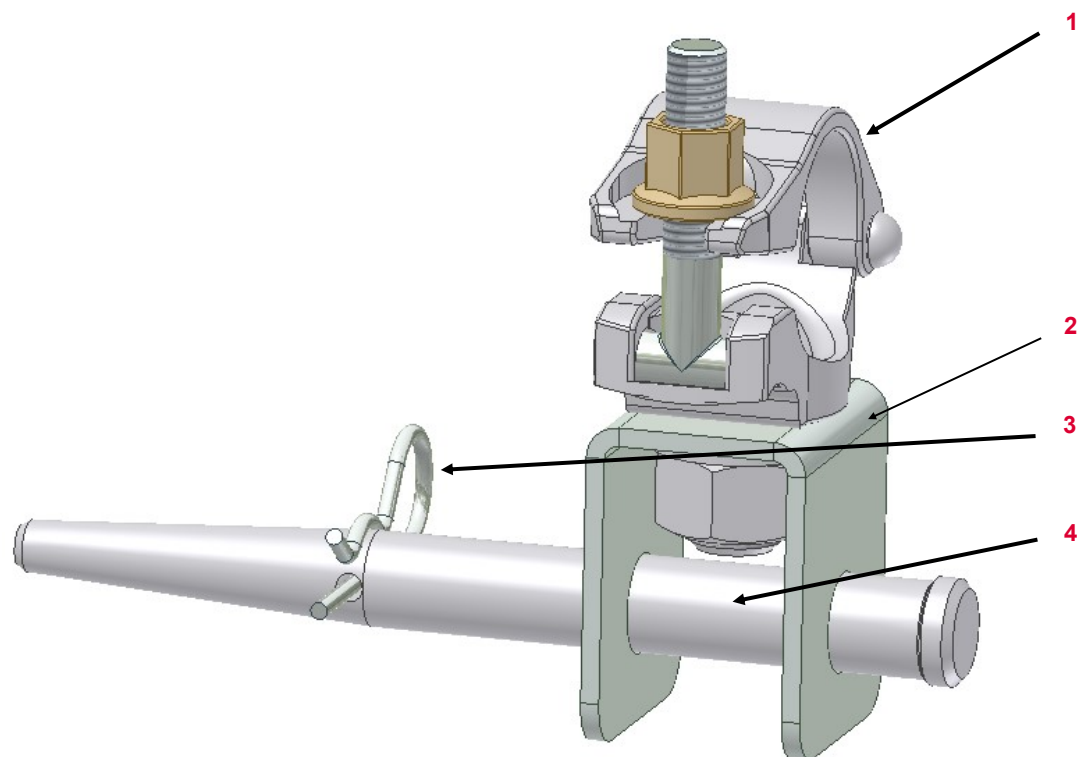



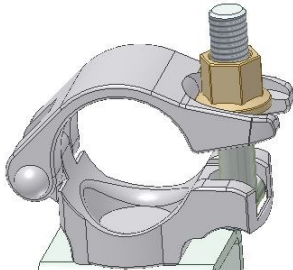



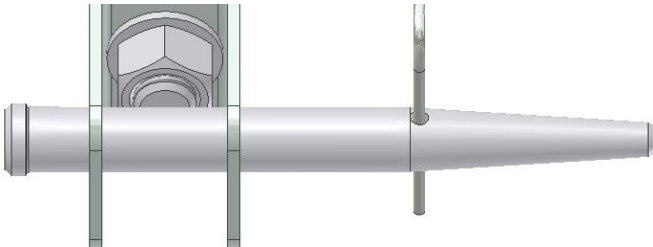

ALPHAKIT

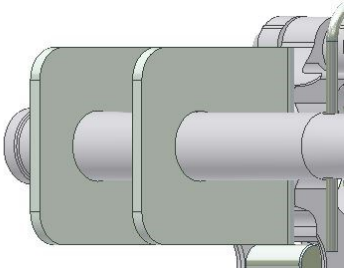

Adaptér lešenářské trubky Ø 48 Alpha (130045)	Číslo	Název	Číslo výrobku
---	-------	-------	---------------



1	Spojka	017040
2	Rám	
3	Závlačka 4/1	018060
4	Čep 21x120	104031

Adaptér lešenářské trubky Ø 48 Alpha	Popis	Instrukce	Fakturace	Typ		
	04.16.35 Chybějící spojka poškozená	 017040 (Spojka)				
	04.16.36 Čep 21x120	<ul style="list-style-type: none"> ■ Chybí 	 104031 (Čep 21x120) 018060 (Závlačka 4/1)			
	<ul style="list-style-type: none"> ■ Nelze použít 	 104031 (Čep 21x120) 018060 (Závlačka 4/1)				
	04.16.37 Ohnutý adaptér trubky	<ul style="list-style-type: none"> ■ Je-li možno 			088244	
	<ul style="list-style-type: none"> ■ Nelze opravit 					

PERI Nájemní kritéria

ALPHAKIT



Žebřík 180/6 051410) | Žebřík 180/2 (103724) Popis Instrukce Fakturace Typ

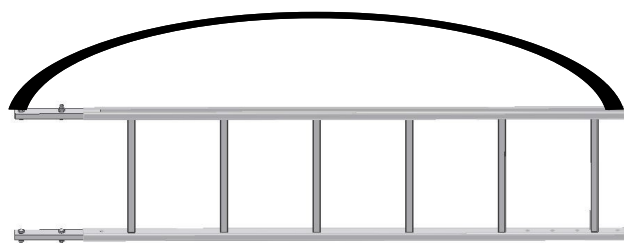

04.16.38 Ohnutý

■ > 5 mm

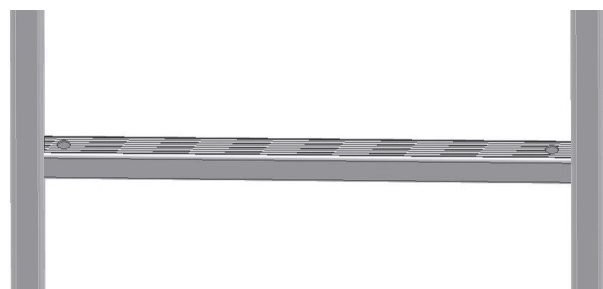

04.16.39 Promáčknutí v profilu

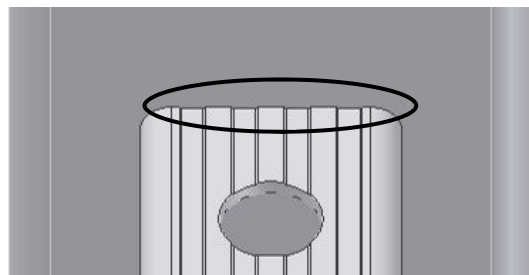

04.16.40 Prasklý svár



Podpěrná spojka (130332)	Popis	Instrukce	Fakturace	Typ
--------------------------	-------	-----------	-----------	-----

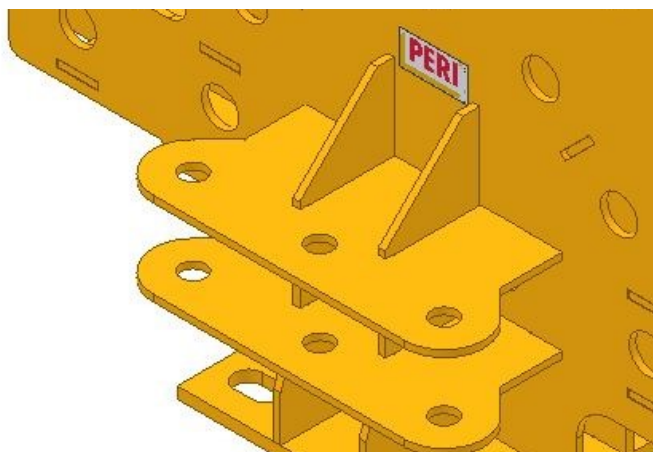

04.16.41 Ohnuté plochy



088244

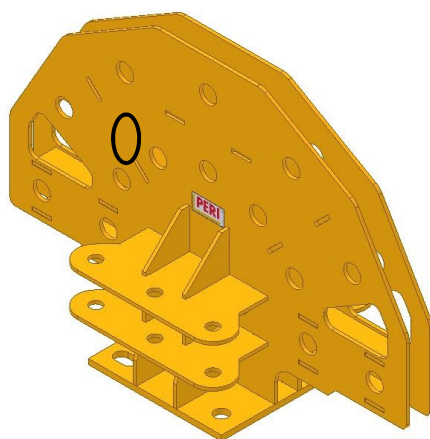

04.16.42 Promáčknutý profil











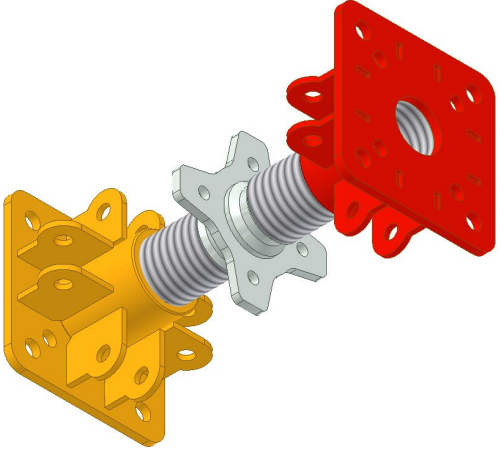

■ >5 mm hloubky

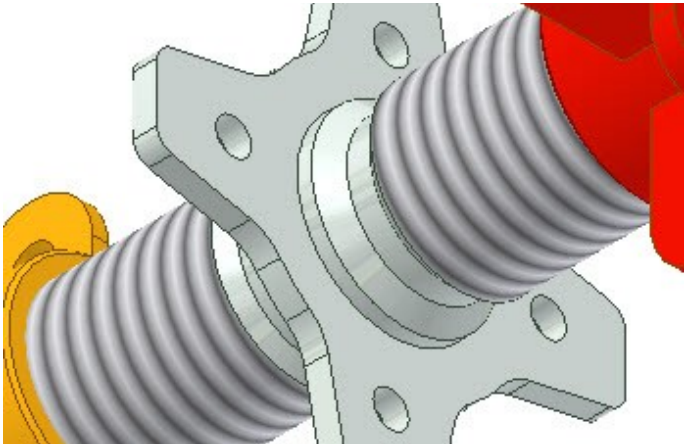

PERI Nájemní kritéria

ALPHAKIT



Vřeteno ATS 360-550 (135438)	Popis	Instrukce	Fakturace	Typ
	<p>Ohnutá patka</p> <ul style="list-style-type: none"> • Lze narovnat • Nelze narovnat 	<p>   Základní patka pravá (135437)  Základní patka levá (135435) </p>	<p>   </p>	<p>   </p>
	<ul style="list-style-type: none"> ■ Poškozené vřeteno (nefunkční) 	<p>  Vřeteno (135436) </p>	<p>  </p>	<p>  </p>

PERI Nájemní kritéria

ALPHAKIT





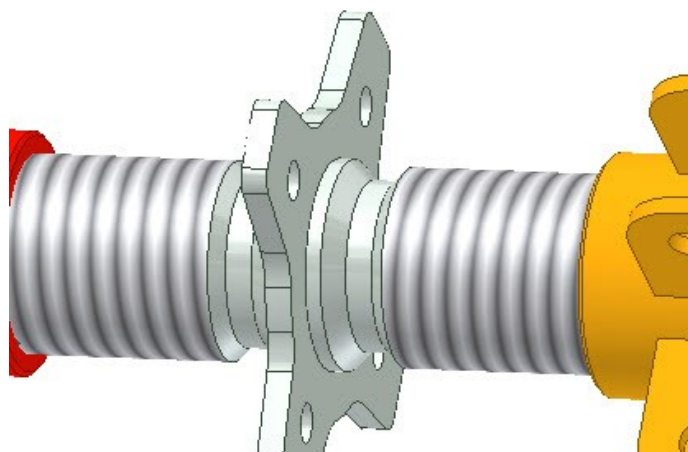



Vřeteno ATS 360-550 (135438)	Popis	Instrukce	Fakturace	Typ
------------------------------	-------	-----------	-----------	-----

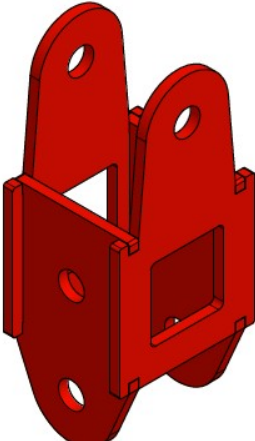

Znečištěné vřeteno



Výztužná spojka VARIOKIT (137531)	Popis	Instrukce	Fakturace	Typ
	Ohnuté úchyty			
	<ul style="list-style-type: none"> Lze narovnat 			
	<ul style="list-style-type: none"> Nelze narovnat (nebo prasklý svár) 			

Výztužná příčná trubka VARIOKIT (137533)	Popis	Instrukce	Fakturace	Typ
--	-------	-----------	-----------	-----

Ohnuté úchyty

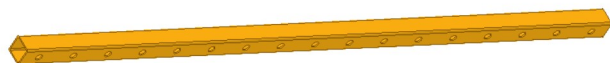

- Lze narovnat
- Nelze narovnat (nebo prasklý svár)





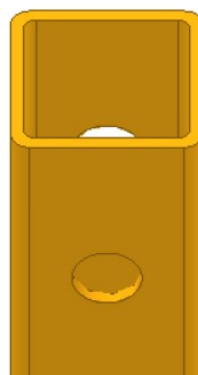





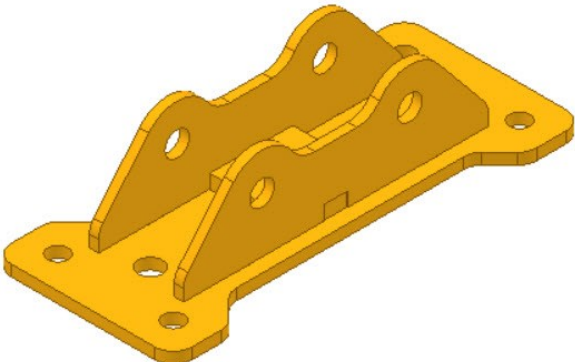





Deformovaná trubka

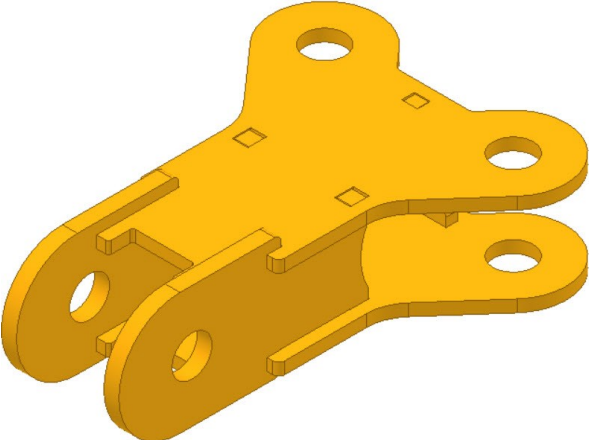

- Lze narovnat
- Nelze narovnat



Výztužná patka VARIOKIT (137527)	Popis	Instrukce	Fakturace	Typ
	Ohnuté úchyty			
	<ul style="list-style-type: none"> Lze narovnat 			
	<ul style="list-style-type: none"> Nelze narovnat (nebo prasklý svár) 	 		

Y- Adaptér VARIOKIT (137527)	Popis	Instrukce	Fakturace	Typ
	<p>Ohnuté úchyty</p> <ul style="list-style-type: none"> <li data-bbox="882 571 1106 603">• Lze narovnat <li data-bbox="882 722 1205 786">• Nelze narovnat (nebo prasklý svár) 	<p data-bbox="1310 544 1377 612"></p> <p data-bbox="1310 683 1449 751"></p>	<p data-bbox="1807 544 1874 612"></p> <p data-bbox="1807 683 1874 751"></p>	<p data-bbox="2092 544 2161 612"></p> <p data-bbox="2092 683 2161 751"></p>

Kloubový klíč DW 15 (137538)	Popis	Instrukce	Fakturace	Typ
------------------------------	-------	-----------	-----------	-----

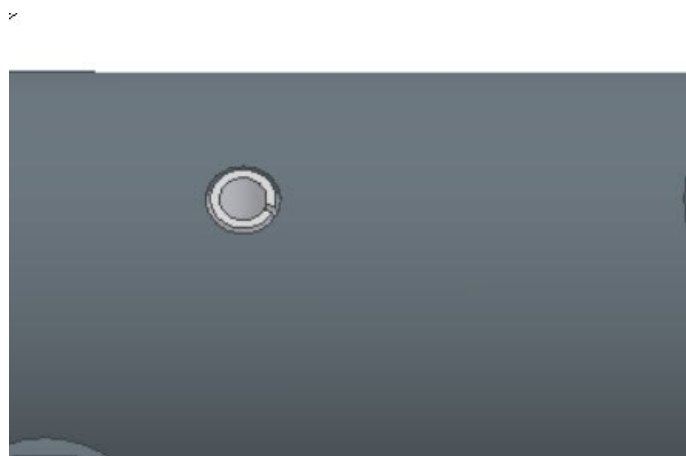

Pružný kolík chybí





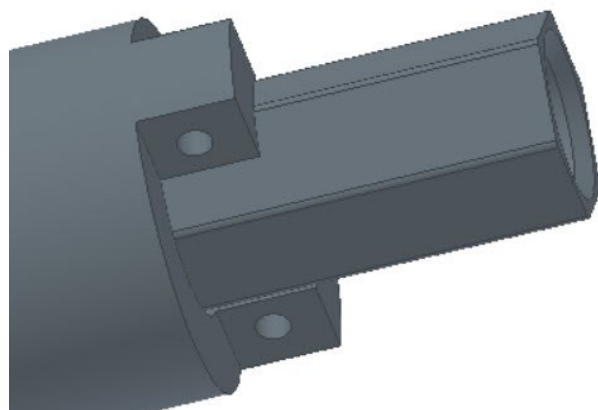



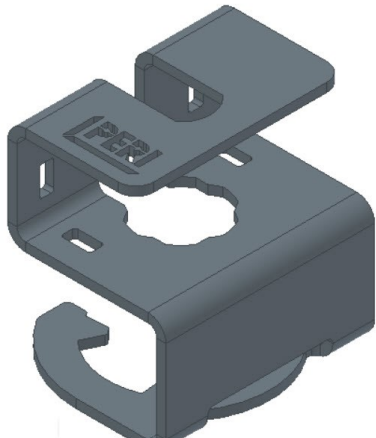

138010



Opotřebovaná šestihránná matice



Otočný zámek kloubového klíče (137939)	Popis	Instrukce	Fakturace	Typ
	Ohnuté úchyty			
	<ul style="list-style-type: none"> Lze narovnat 			
	<ul style="list-style-type: none"> Nelze narovnat 	 		

PERI Nájemní kritéria

Vysvětlivky



Znak	Význam	Znak	Význam	Znak	Význam
	Není v pořádku – materiál je poškozený		Fakturuje se zákazníkovi		Optické poškození
	OK – materiál zůstává v nájemním skladu		Nefakturuje se zákazníkovi		Funkční poškození
	Poškozený materiál – není dovoleno vydávat materiál z bezpečnostních důvodů		Zkrácení prvku		Funkční poškození — není dovoleno vydávat materiál z bezpečnostních důvodů
	Oprava dle instrukcí		Označení prvku barvou		Statické poškození — není dovoleno vydávat materiál z bezpečnostních důvodů
	Oprava za studena — poté kontrola svárů a sousedních dílů		Výměna poškozeného dílu		
	Oprava po výpočtu hospodárnosti		Doplnění chybějícího dílu		
	Očištění materiálu				