

# PERI Nájemní kritéria

## VST

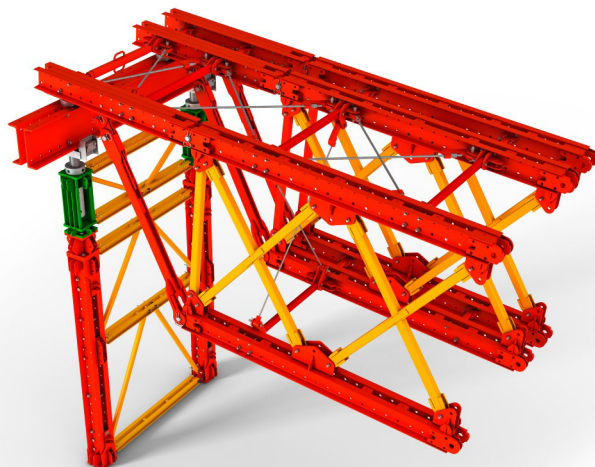

### Kontakt

**PERI, spol. s r.o.**  
**Bednění Lešení Služby**

Průmyslová 392  
252 42 Jesenice u Prahy  
tel.: 222 359 311  
fax: 222 359 315  
info@peri.cz

Obsah	Strana	Poslední změny	Datum  Iničiály	Strana
Kolejnice NKS	2	Nová verze	01/2016 I fw	
Ocelová závora SRU	7			
Podpěrné vřeteno SLS	13			
Příslušenství	16			
Vysvětlivky znaků	36			

# PERI Nájemní kritéria

## VST



### Kolejnice NKS

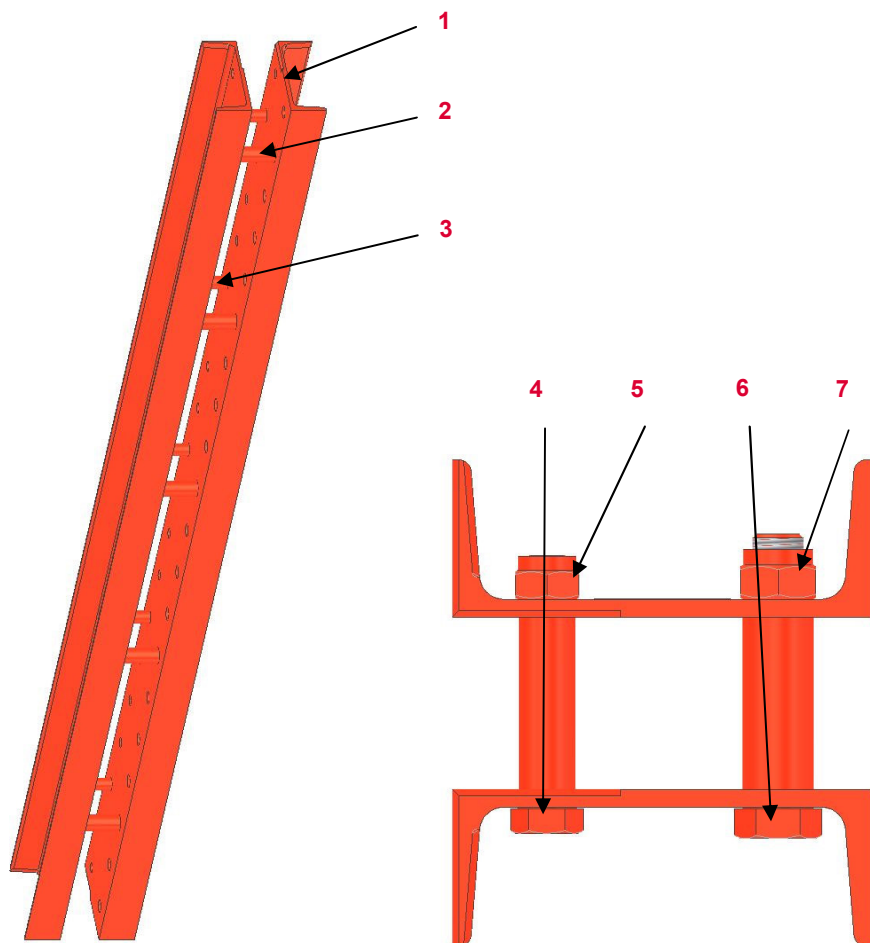

Č.	Popis	Číslo výrobku
1	Kolejnice	
2	Trubka 33,7	109642
3	Trubka 26,9	109645
4	Šroub M 20x120	104477
5	Matice M 20	781053
6	Šroub M 24x130	109612
7	Matice M 24	105032

Platné pro	Číslo výrobku
Kolejnice NKS 148	114166
Kolejnice NKS 248	109469
Kolejnice NKS 298	112102
Kolejnice NKS 348	109470
Kolejnice NKS 498	109471
Kolejnice NKS 748	109472
Kolejnice NKS 998	109610

Kolejnice NKS	Popis	Instrukce	Fakturace	Typ
---------------	-------	-----------	-----------	-----

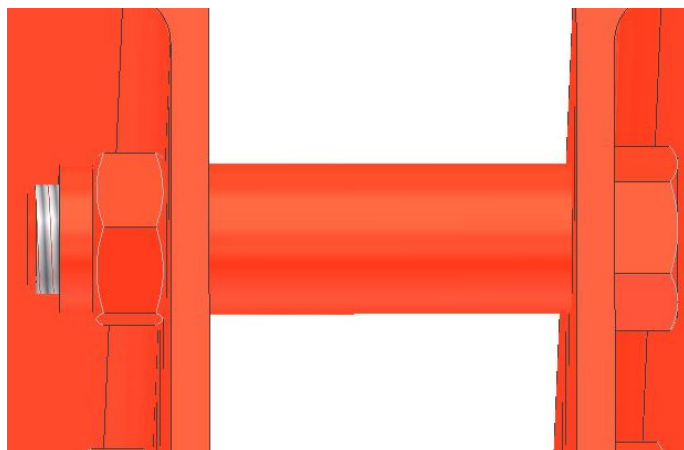

### 04.17.01 Distančník

- Chybí
- Nebo je chybně umístěn



Přesun distančníku



088779 (M 20)  
088780 (M 24)



088436



### 04.17.02 Kolejnice Řez

- Zkrátit na další délku– prosím kontaktujte logistické oddělení

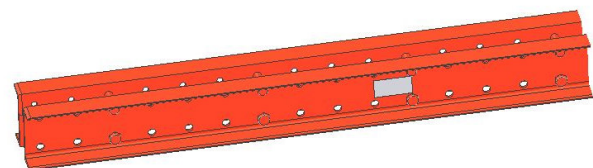

Kolejnice NKS	Popis	Instrukce	Fakturace	Typ
---------------	-------	-----------	-----------	-----

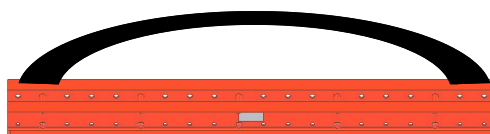

### 04.17.03 Ohnutí ve slabší středové linii (linie z)

■ ≤ Povolené ohnutí (l/500)



■ Nebo > Povolené ohnutí (l/500)

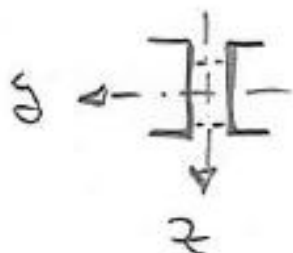

Platné pro	Trvalé ohnutí
Kolejnice NKS 148	6 mm
Kolejnice NKS 248	6 mm
Kolejnice NKS 298	6 mm
Kolejnice NKS 348	7 mm
Kolejnice NKS 498	10 mm
Kolejnice NKS 748	15 mm
Kolejnice NKS 998	20 mm

Kolejnice NKS	Popis	Instrukce	Fakturace	Typ
---------------	-------	-----------	-----------	-----

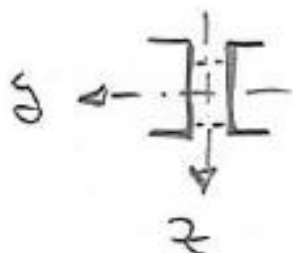
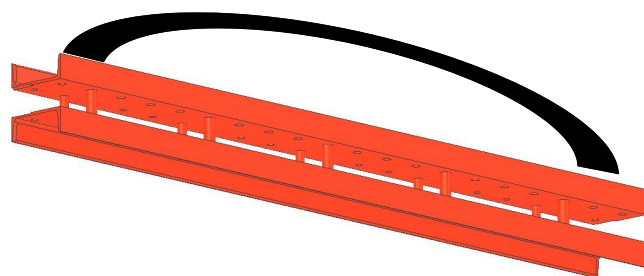

### 04.17.04 Ohnutí v silnější středové linii (linie y)

- ≤ Povolené ohnutí (l/ 500)
- Nebo > Povolené ohnutí (l/ 500)



Platné pro	Trvalé ohnutí
Kolejnice NKS 148	6 mm
Kolejnice NKS 248	6 mm
Kolejnice NKS 298	6 mm
Kolejnice NKS 348	7 mm
Kolejnice NKS 498	10 mm
Kolejnice NKS 748	15 mm
Kolejnice NKS 998	20 mm

# PERI Nájemní kritéria

## VST

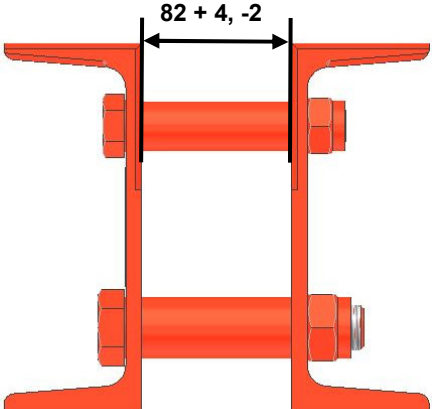

Kolejnice NKS	Popis	Instrukce	Fakturace	Typ
	04.17.05 Promáčknutí v profilu		088244	
	04.17.06 Vzdálenost mezi profily je mimo toleranci			

### Ocelová závora SRU

Č.	Popis	Číslo výrobku
----	-------	---------------

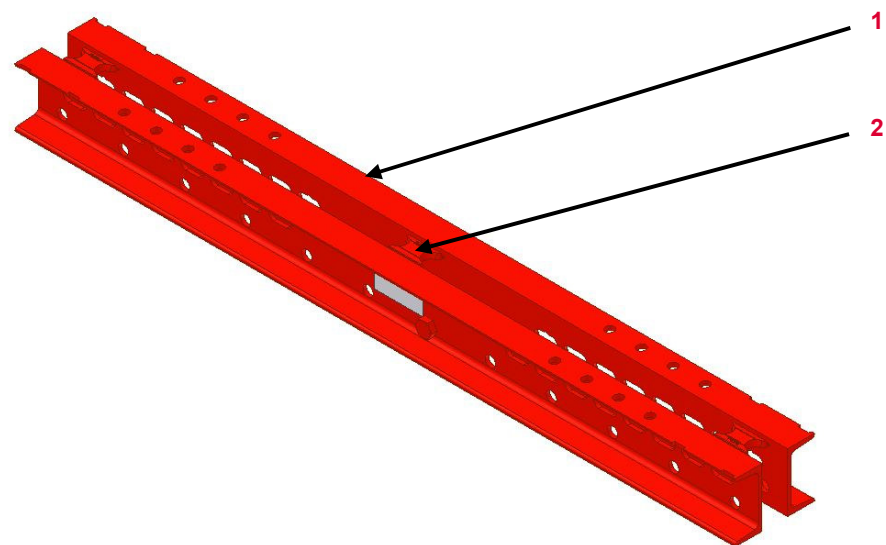

1	Profil	
2	Distančník SRU	103815
3	Distanční trubka	108768
4	Šroub M 20 x 90	710226
5	Matice M 20	781053

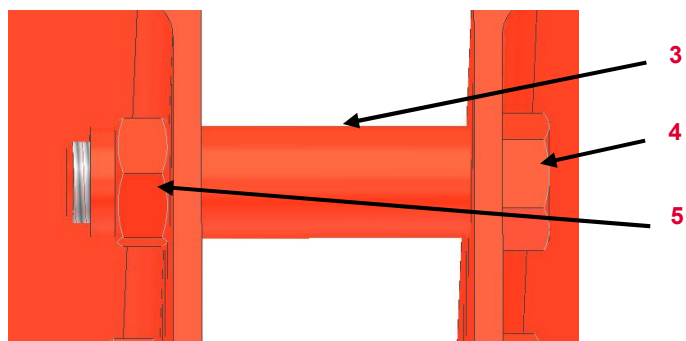

# PERI Nájemní kritéria

## VST



Platné pro	Číslo výrobku
Ocelová závora SRU U 120, L= 0,72 m	103868
Ocelová závora SRU U 120, L= 0,97 m	103871
Ocelová závora SRU U 120, L= 1,22 m	103874
Ocelová závora SRU U 120, L= 1,47 m	103877
Ocelová závora SRU U 120, L= 1,72 m	103886
Ocelová závora SRU U 120, L= 1,97 m	103889
Ocelová závora SRU U 120, L= 2,22 m	103898
Ocelová závora SRU U 120, L= 2,47 m	103892
Ocelová závora SRU U 120, L= 2,72 m	103929
Ocelová závora SRU U 120, L= 2,97 m	103903
Ocelová závora SRU U 120, L= 3,47 m	103906
Ocelová závora SRU U 120, L= 3,97 m	103915
Ocelová závora SRU U 120, L= 4,47 m	103918
Ocelová závora SRU U 120, L= 4,97 m	103922

Platné pro	Číslo výrobku
Ocelová závora SRU U 120, L= 5,47 m	103925
Ocelová závora SRU U 120, L= 5,97 m	103928



Ocelová závora SRU	Popis	Instrukce	Fakturace	Typ
--------------------	-------	-----------	-----------	-----



04.17.07 Distančník Chybí| Odříznut



088823

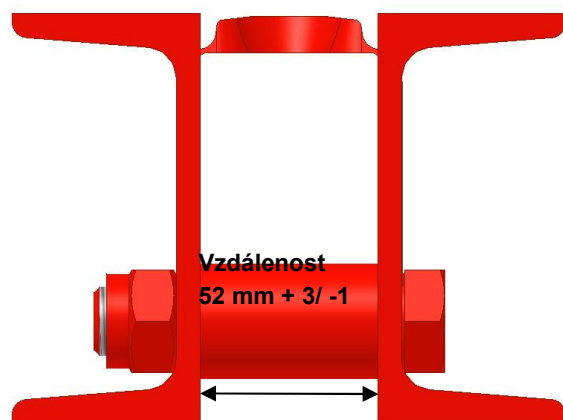













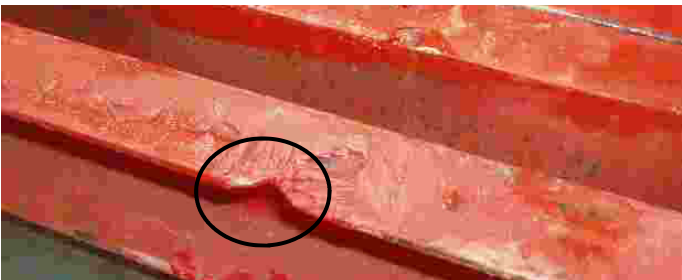

04.17.08 Vzdálenost mezi profily je mimo toleranci



# PERI Nájemní kritéria

## VST



Ocelová závora SRU	Popis	Instrukce	Fakturace	Typ
	04.17.09 Uříznuté	 		
	04.17.10 Naříznuté	 		
	04.17.11 Vyvrtané díry	 		

Ocelová závora SRU	Popis	Instrukce	Fakturace	Typ
	<b>04.17.12 Zkosený konec profilu</b>			
	<ul style="list-style-type: none"> <li>■ Původní délka zachována</li> <li>■ Nebo délka změněna</li> </ul>	 	 	 
	<b>04.17.13 Ohnutý konec profilu</b>			
	<ul style="list-style-type: none"> <li>■ Je-li možné</li> <li>■ Není-li možné opravit</li> </ul>	 	088244 	 
	<b>04.17.14 Promáčknutí v profilu</b>			
	<ul style="list-style-type: none"> <li>■ Je-li možné</li> <li>■ Není-li možné opravit</li> </ul>	 	088244 	 

Ocelová závora SRU	Popis	Instrukce	Fakturace	Typ
--------------------	-------	-----------	-----------	-----

Z- středová linie

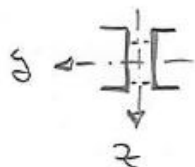
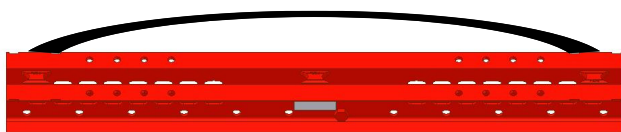

Y- středová linie

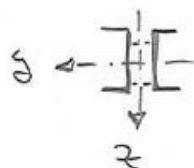

### 04.17.15 SRU ohnuté

■ ≤ povolené ohnutí (l/ 500)



■ > povolené ohnutí (l/ 500)







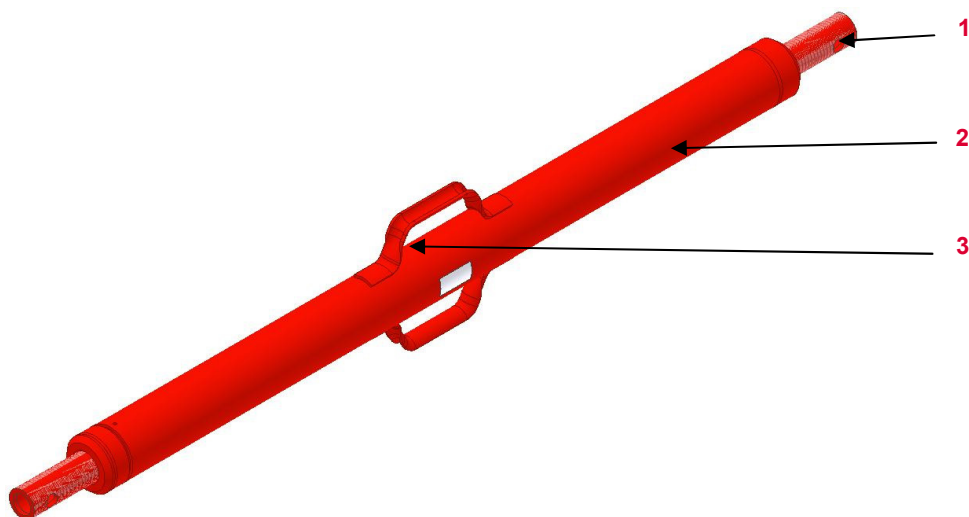



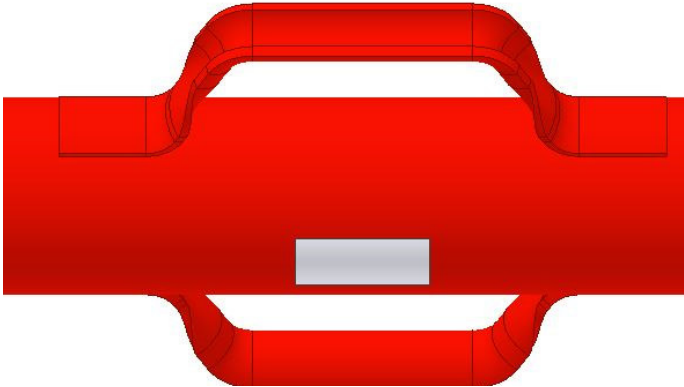

Artikl	Povolené ohnutí
SRU L= 0,72 - 1,72	3,0 mm
SRU L= 1,97; 2,22-	4,0 mm
SRU L= 2,47; 2,72	5,0 mm
SRU L= 2,97	6,0 mm
SRU L= 3,47	7,0 mm
SRU L= 3,97	8,0 mm
SRU L= 4,47	9,0 mm
SRU L= 4,97	10,0 mm
SRU L= 5,47	11,0 mm
SRU L= 5,97	12,0 mm

Podpěrné vřeteno SLS	Č.	Popis	Číslo výrobku
----------------------	----	-------	---------------

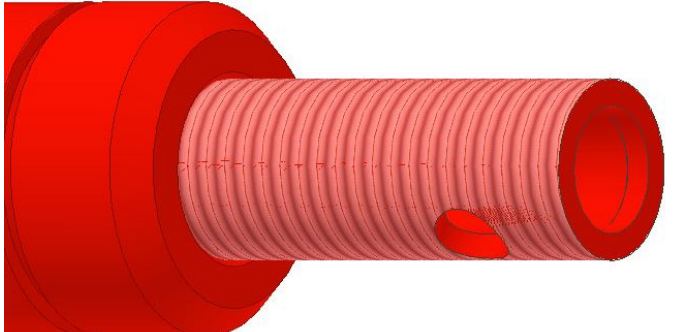

1	Vřeteno	
2	Vnější trubka	
3	Držadlo	117471

Platné pro	Číslo výrobku
Podpěrné vřeteno SLS40/80	111035
Podpěrné vřeteno SLS80/140	101773
Podpěrné vřeteno SLS100/180	101774
Podpěrné vřeteno SLS140/240	101776
Podpěrné vřeteno SLS200/300	101778
Podpěrné vřeteno SLS260/360	101779
Podpěrné vřeteno SLS320/420	109726
Podpěrné vřeteno SLS380/480	109785

Podpěrné Vřeteno	Popis	Instrukce	Fakturace	Typ
	<b>04.17.16 Poškozené držadlo   Chybí</b>			
	<b>04.17.17 Vřeteno</b>  <ul style="list-style-type: none"> <li>■ Obtížný pohyb kvůli znečištění</li> <li>■ Nebo není možný pohyb kvůli poškození vnější trubky</li> </ul>	  	  	  

Podpěrné Vřeteno	Popis	Instrukce	Fakturace	Typ
------------------	-------	-----------	-----------	-----



04.17.18 Ohnuté vřeteno

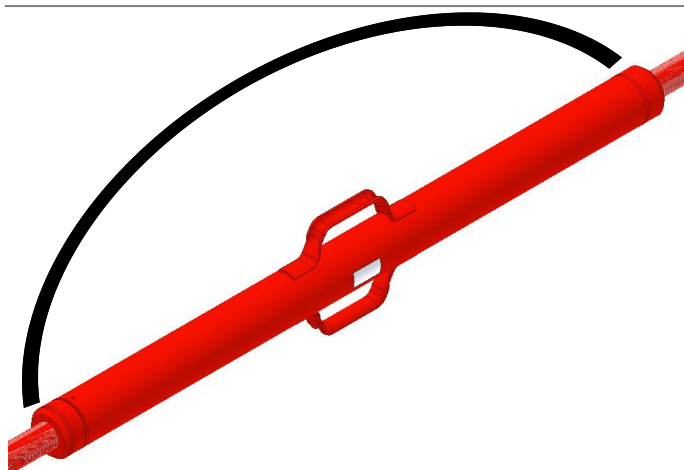

04.17.19 Ohnutá vnější trubka

■ > Povolené ohnutí



Artikl	Povolené ohnutí
SLS 40/80; 80/140; 100/180; 140/240	3,0 mm
SLS 200/300	4,0 mm
SLS 260/360	5,0 mm
SLS 320/420	6,0 mm
SLS 380/480	7,0 mm

# PERI Nájemní kritéria

## VST





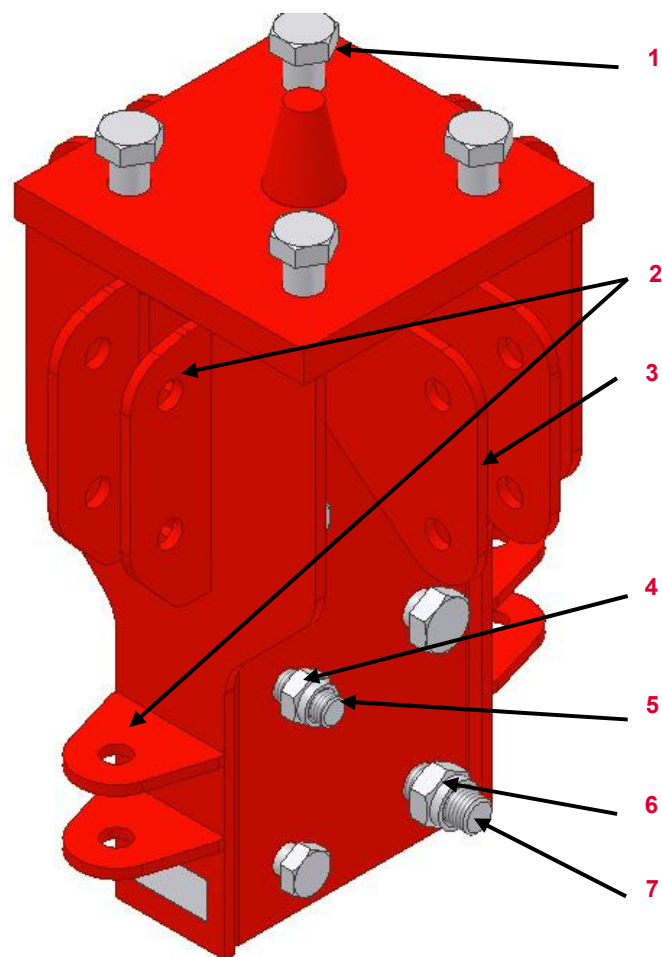















### Sloupová spojka VST 48 (117454)



Č.	Popis	Číslo výrobku
1	Šroub M 24x80	105416
2	Napojovací deska vnitřní	
3	Napojovací deska vnější	
4	Šroub M 20	781053
5	Šroub M 20x130	117452
6	Matice M 24	105032
7	Šroub M 24x130	114563



Nápojovací desky	Popis	Instrukce	Fakturace	Typ
	<b>04.17.20 Ohnutá vnější nápojovací deska</b>	<ul style="list-style-type: none"> <li>■ Je-li možné </li> </ul>	 088244	
	<ul style="list-style-type: none"> <li>■ Nebo není-li možné opravit</li> </ul>			
	<ul style="list-style-type: none"> <li>■ Nebo jsou praskliny ve svárech</li> </ul>			
	<b>04.17.21 Ohnutá vnitřní nápojovací deska</b>	<ul style="list-style-type: none"> <li>■ Je-li možné (upevňovací díly mohou být namontovány) </li> </ul>	 088244	
	<ul style="list-style-type: none"> <li>■ Nebo není-li možné opravit (upevňovací díly nemohou být namontovány)</li> </ul>	 		

# PERI Nájemní kritéria







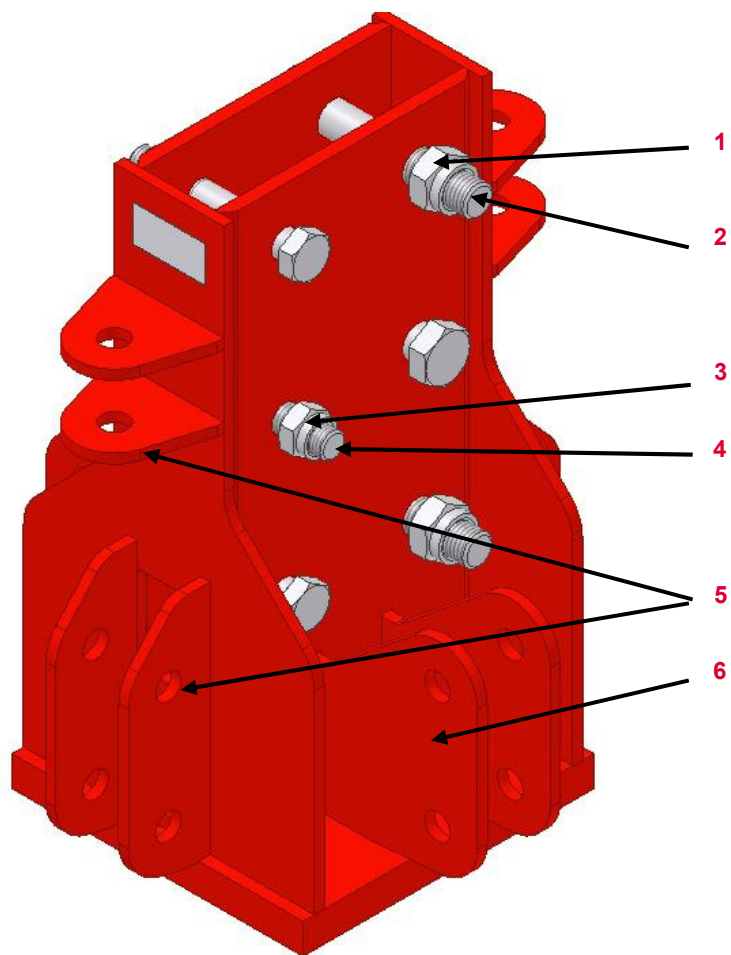







## VST



### Patka VST 48 (117453)



Č.	Popis	Číslo výrobku
1	Šroub M 24	105032
2	Šroub M 24x140	114563
3	Matice M 20	781053
4	Šroub M 20x130	117452
5	Napojovací deska vnější	
6	Napojovací deska vnitřní	

Nápojovací desky	Popis	Instrukce	Fakturace	Typ
	<b>04.17.22 Ohnutá vnější nápojovací deska</b>	<ul style="list-style-type: none"> <li>■ Je-li možné</li> </ul>	 088244	
	<ul style="list-style-type: none"> <li>■ Nebo není-li možné opravit</li> </ul>			
	<ul style="list-style-type: none"> <li>■ Nebo jsou praskliny ve svárech</li> </ul>			
	<b>04.17.23 Ohnutá vnitřní nápojovací deska</b>	<ul style="list-style-type: none"> <li>■ Je-li možné (upevňovací díly mohou být namontovány)</li> </ul>	 088244	
	<ul style="list-style-type: none"> <li>■ Nebo není-li možné opravit (upevňovací díly nemohou být namontovány)</li> </ul>			

# PERI Nájemní kritéria

## VST



### Hlava VST 100 (117465)

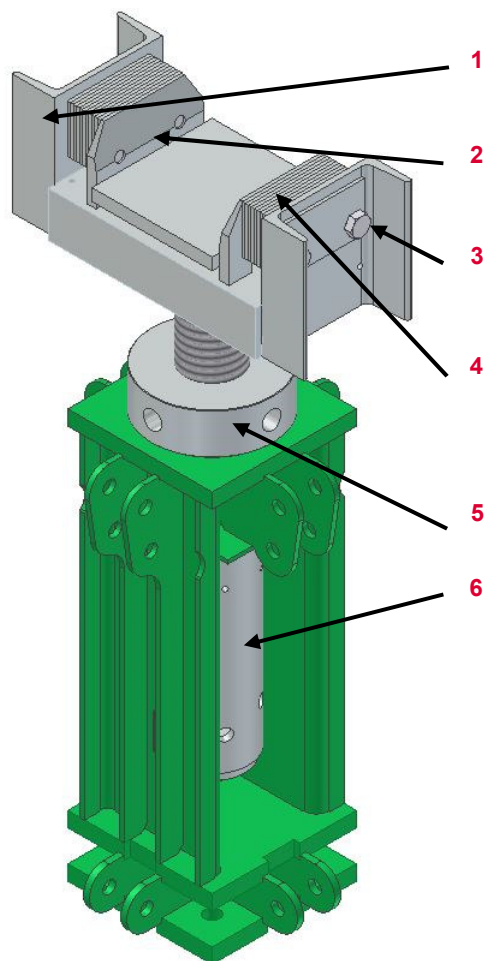

Č.	Popis	Číslo výrobku
1	Vidlice poz.	117464
2	Středová deska	117441
3	Šroub M 20x80	024900
4	Distanční deska	117439
5	Matice k vřetenu	117457
6	Vřeteno	117551











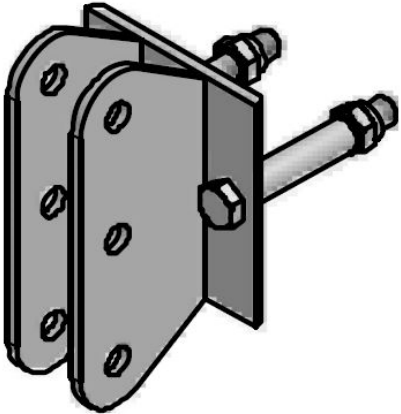





Hlava VST	Popis	Instrukce	Fakturace	Typ
	<b>04.17.24 Ohnutý U- Profil</b>  <ul style="list-style-type: none"> <li>■ Je-li možné</li> </ul>		088244	
	<ul style="list-style-type: none"> <li>■ Nebo není-li možné opravit</li> </ul>	Vidlice (117464)		
	<b>04.17.25 Prasklina ve sváru na vidlici</b>	Vidlice (117464)		
	<b>04.17.26 Distanční deska</b>  <ul style="list-style-type: none"> <li>■ Ohnutá</li> </ul>		088244	
	<ul style="list-style-type: none"> <li>■ Nebo chybí</li> </ul>	117439 (Distanční deska)		

Hlava VST	Popis	Instrukce	Fakturace	Typ
	<p><b>04.17.27 Závít</b></p> <ul style="list-style-type: none"> <li>■ Těžce znečištěné</li> <li>■ Nebo poškozený závít</li> </ul>	 	 	 
	<p><b>04.17.28 Ohnutí napojovacích desek</b></p> <ul style="list-style-type: none"> <li>■ Je-li možné</li> <li>■ Nebo není-li možné opravit</li> </ul>	 	088244 	 
	<p><b>04.17.29 Vřeteno není pohyblivé</b></p>	Vřeteno (117551)		

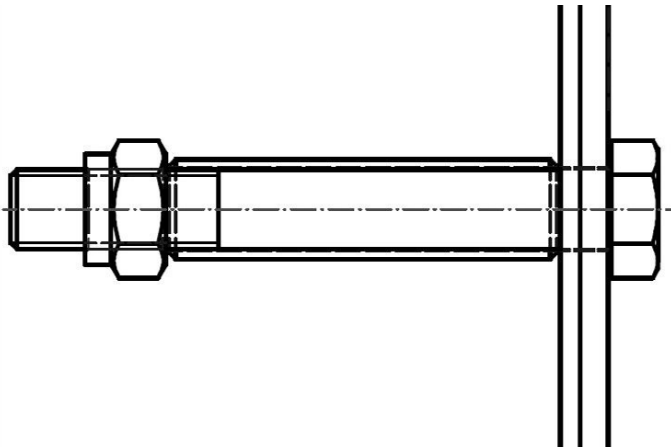
Výškový adaptér VST 25 (117391)	Popis	Instrukce	Fakturace	Typ	
	<b>04.17.30 Ohnutý výškový adaptér</b>	<ul style="list-style-type: none"> <li>■ Je-li možné</li> </ul>	088244		
	<ul style="list-style-type: none"> <li>■ není-li možné opravit</li> </ul>				
	<ul style="list-style-type: none"> <li>■ jsou praskliny ve svárech</li> </ul>				
	<b>04.17.31 Šroub</b>	<ul style="list-style-type: none"> <li>■ Není pohyblivý</li> </ul>	105032 (Matice) 105416 (Šroub)	088025	
	<ul style="list-style-type: none"> <li>■ Nebo chybí</li> </ul>	105032 (Matice) 105416 (Šroub)	088025		

Výškový adaptér VST 12,5 (117433)	Popis	Instrukce	Fakturace	Typ
	<b>04.17.32 Ohnutý výškový adaptér</b>			
	<ul style="list-style-type: none"> <li>■ Je-li možné</li> </ul>		088244	
	<ul style="list-style-type: none"> <li>■ není-li možné opravit</li> </ul>			
	<ul style="list-style-type: none"> <li>■ jsou praskliny ve svárech</li> </ul>			
	<b>04.17.33 Šroub Matice</b>			
	<ul style="list-style-type: none"> <li>■ Není pohyblivý</li> </ul>	117429 (Šroub) 105032 (Matice)	088025	
	<ul style="list-style-type: none"> <li>■ je ohnutý</li> </ul>	117429 (Šroub) 105032 (Matice)	088025	
	<ul style="list-style-type: none"> <li>■ Chybí</li> </ul>	117429 (Šroub) 105032 (Matice)	088025	



Příčná spojka VST (117425)	Popis	Instrukce	Fakturace	Typ
	<b>04.17.34 Ohnutá spojka</b>			
	<ul style="list-style-type: none"> <li>■ Je-li možné</li> </ul>		 088244	
	<ul style="list-style-type: none"> <li>■ není-li možné opravit</li> </ul>			
	<ul style="list-style-type: none"> <li>■ jsou praskliny ve svárech</li> </ul>			
	<b>04.17.35 Šrouby</b>			
	<ul style="list-style-type: none"> <li>■ Promáčknutí</li> </ul>		 088025	
	<ul style="list-style-type: none"> <li>■ Chybí</li> </ul>		 088025	

# PERI Nájemní kritéria

## VST



Vazbová spojka VST (117411)	Popis	Instrukce	Fakturace	Typ
-----------------------------	-------	-----------	-----------	-----

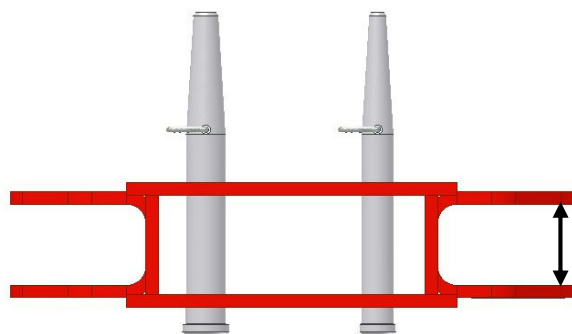

Daný rozměr 52 mm

04.17.36 Ohnutý kryt



088244

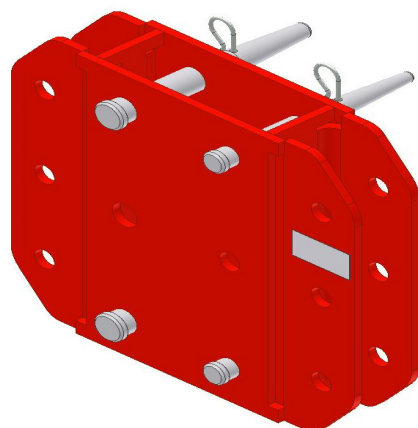

04.17.37 Čep

■ Čep Ø 21 x 120 Chybí



104031 (Čep Ø 21 x 120)  
018060 (Závlačka 4/1)











■ Čep Ø 26 x 120 chybí



111567 (Čep Ø 26 x 120)  
022230 (Závlačka 5/1)



Horizontála VST 200 (117371)	Popis	Instrukce	Fakturace	Typ
	<b>04.17.38 Uřezané přehozy</b>			
	<b>04.17.39 Ohnutá výztuha</b> ■ > 4,0 mm (/500)			
	<b>04.17.40 Ohnutá   Nařiznutá</b>			
	<b>04.17.41 Ohnutý U- profilu</b> ■ ≤ 5 mm ■ > 5 mm		088244 	 

Horizontální diagonála VST (117504)	Popis	Instrukce	Fakturace	Typ
	<p>04.17.42 Ohnutá</p> <p>■ &gt; 5 mm (/500)</p>			
	<p>04.17.43 Průhyb v trubce</p>			

# PERI Nájemní kritéria VST



Diagonály VST	Platné pro	Číslo výrobku
---------------	------------	---------------

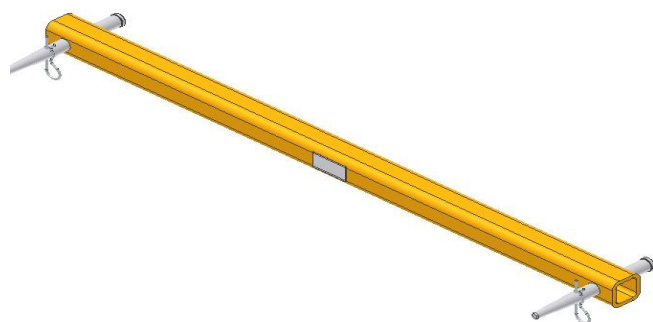

Diagonála VST 200/ 62,5	117388
Diagonála VST 200/ 100	117382
Diagonála VST 200/ 112,5	117385
Diagonála VST 200/ 150	117379

Poškození	Popis	Instrukce	Fakturace	Typ
-----------	-------	-----------	-----------	-----

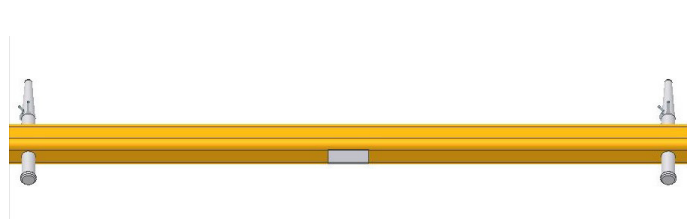

#### 04.17.44 Ohnutí

■ > 3 mm (l/ 500)















#### 04.17.45 Průhyb v trubce

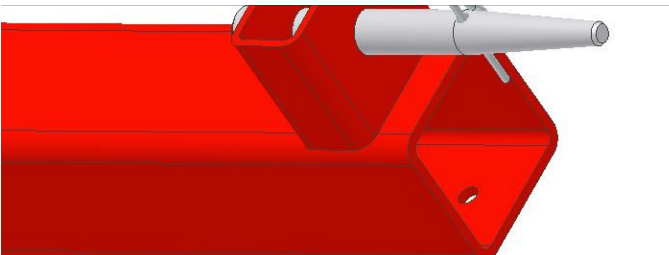

# PERI Nájemní kritéria

## VST



Horizontální spojka dlouhá VST (117712)	Popis	Instrukce	Fakturace	Typ
	<p><b>04.17.46 Ohnutá</b></p> <p>■ &gt; 6 mm (l/500)</p>			
	<p><b>04.17.47 Průhyb v trubce</b></p>			
	<p><b>04.17.48 Průhyb v trubkové spojce</b></p>			

Adapter VST- SRU (123823)	Popis	Instrukce	Fakturace	Typ
	<b>04.17.49</b> Promáčknutá trubka  prohnutá   řez			
	<b>04.17.50</b> Čep chybí	104031 (Čep) 018060 (Závlačka)	088178	

# PERI Nájemní kritéria

## VST



Poklesový klín 1000 kN (117930)	Popis	Instrukce	Fakturace	Typ
---------------------------------	-------	-----------	-----------	-----

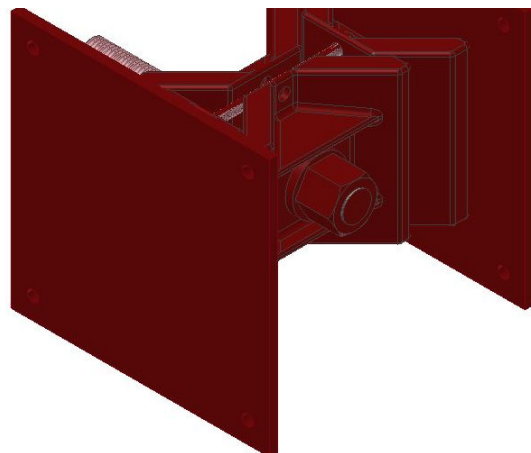

04.17.51 Ohnutý klín



088244

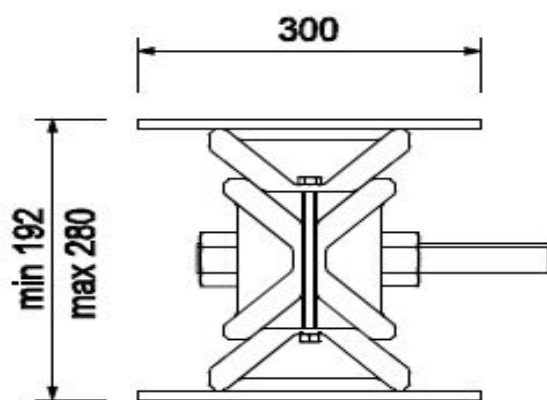

04.17.52 Není funkční





# PERI Nájemní kritéria

## VST



Poklesový klín 420 kN (024590)	Popis	Instrukce	Fakturace	Typ
--------------------------------	-------	-----------	-----------	-----

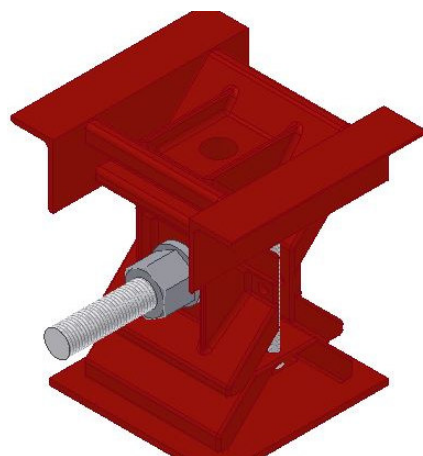

04.17.53 Ohnutý klín



088244

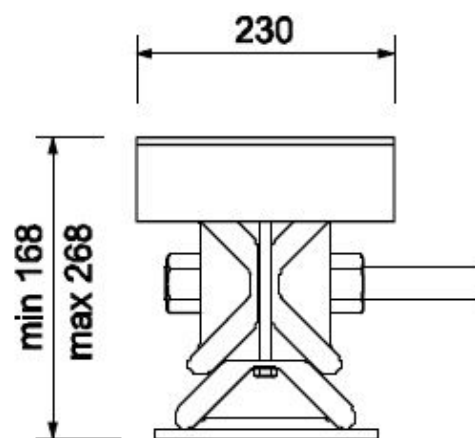

04.17.54 Není funkční



# PERI Nájemní kritéria

## VST



Spojka UP- VST (117707)	Č.	Popis	Číslo výrobku
-------------------------	----	-------	---------------

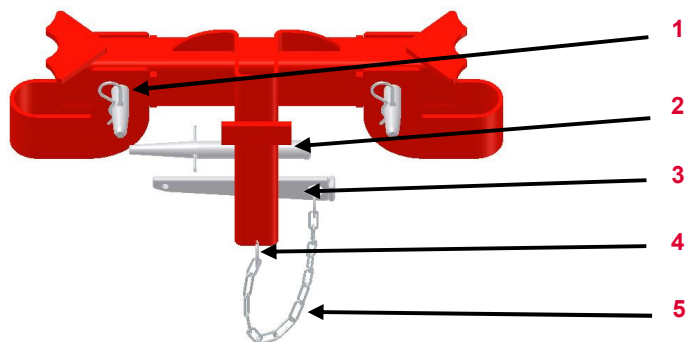

1	Čep 20 x 140	105400
2	Čep 21 x 120	104031
3	Klín	024250
4	Konc. Kolečko a. řetězu poj. voz.	710929
5	Řetěz	107554

Poškození	Popis	Instrukce	Fakturace	Typ
-----------	-------	-----------	-----------	-----



### 04.17.55 Klín

- Ohnutý
- chybí

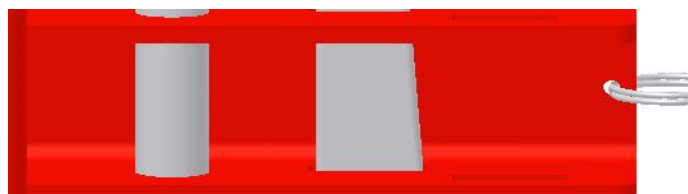

### 04.17.56 Ohnutá napojovací deska

- Je-li možné
- není-li možné opravit











088244

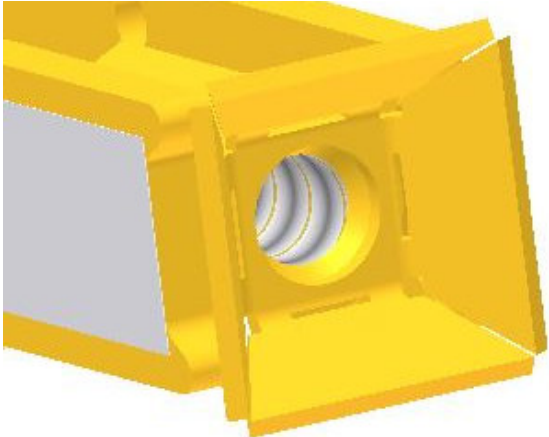

# PERI Nájemní kritéria

## VST

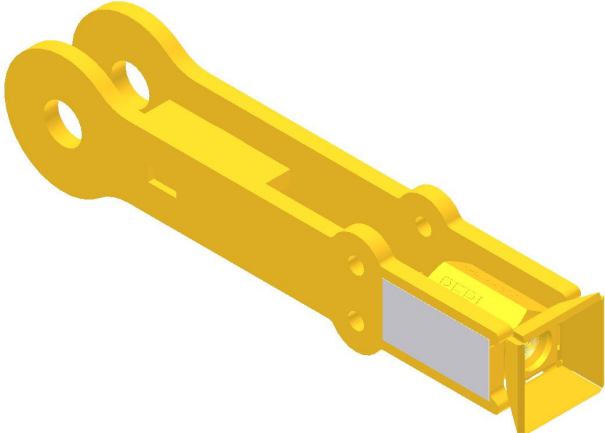

Tie Yoke VARIOKIT (116532)	Popis	Instrukce	Fakturace	Typ	
	<b>04.17.57 Závít</b>				
	<ul style="list-style-type: none"> <li>■ Znečištěné</li> </ul>			 Znovu prožezat závít	
	<b>04.17.58 Ohnuté části</b>			088244	

# PERI Nájemní kritéria

## Vysvětlivky znaků



Znak	Význam	Znak	Význam	Znak	Význam
	Není v pořádku - materiál je poškozený		Fakturuje se zákazníkovi		Optické poškození
	OK– materiál zůstává v nájemním skladu		Nefakturuje se zákazníkovi		Funkční poškození
	Poškozený materiál – <b>není dovoleno</b> vydávat materiál z bezpečnostních důvodů		Zkrácení prvku		Funkční poškození - <b>není dovoleno</b> vydávat materiál z bezpečnostních důvodů
	Oprava dle instrukcí		Označení prvku barvou		Statické poškození - <b>není dovoleno</b> vydávat materiál z bezpečnostních důvodů
	Oprava za studena - poté kontrola svárů a sousedních dílů		Výměna poškozeného dílu		
	Oprava po výpočtu hospodárnosti		Doplnění chybějícího dílu		
	Očištění materiálu				