

PERI Nájemní kritéria MAXIMO

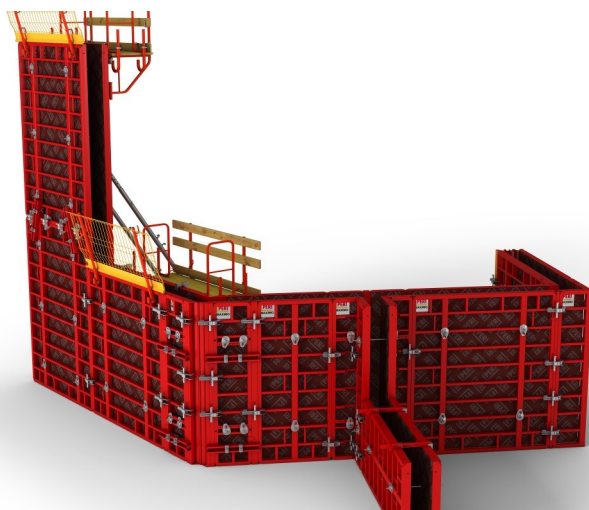

Kontakt

PERI, spol. s r.o.
bednění lešení služby

Průmyslová 392
252 42 Jesenice u Prahy
tel.: 222 359 311
info@peri.cz
www.peri.cz

Obsah	Strana	Změny	Datum Iniciály	Strana
Rám	2	Poslední změny	08/2015 fw	
Kloubový roh	20	MXK a MXP	08/2016 fw	
Šachtový roh	25	Přidáno poškození překližky	03/2022 fw	31
Vložka WDA	34	Přidáno poškození podlah	03/2022 fw	90-91
Příslušenství	46			
Plošina MXP	59			
Podlaha MXK	80			
Konzola MXK	88			
Vysvětlivky	98			

PERI Nájemní kritéria

MAXIMO



MAXIMO Rám	Č.	Popis	Číslo výrobku
------------	----	-------	---------------

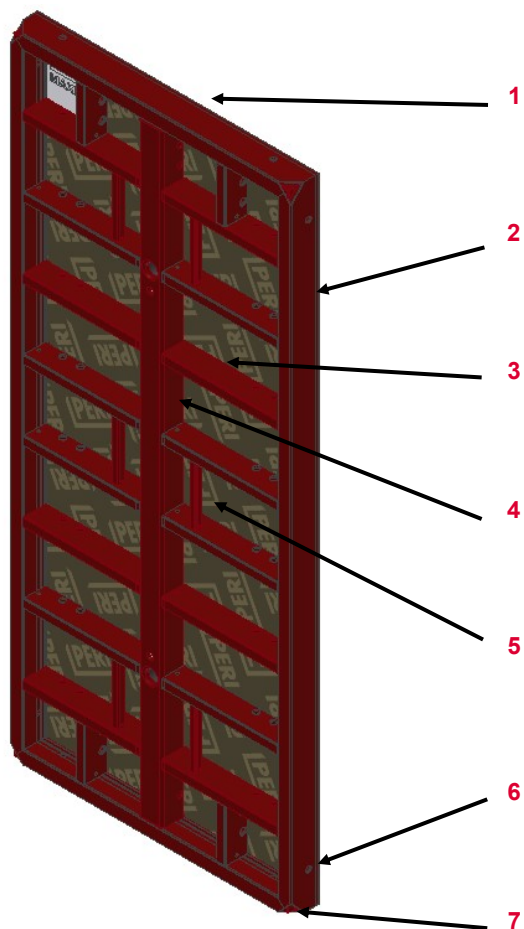

1	Čelní profil	
2	Podélný profil	
3	Žebro	
4	Kotevní žebro	
5	Trubička	111999
6	Lemovací vložka	750120
7	Odbedňovací roh	112337

PERI Nájemní kritéria

MAXIMO



Výrobek	Číslo výrobku
Panel MX 15 330x270	116454
Panel MX 15 330x 40	114426
Panel MX 15 330x120	114248
Panel MX 15 330x90	114258
Panel MX 15 330x60	114445
Panel MX 15 330x45	114452
Panel MX 15 330x30	114457
Panel MXM 15 330x60	114464
Panel MX 15 270x240	112006
Panel MX 15 270x120	112022
Panel MX 15 270x90	112045
Panel MX 15 270x60	112200
Panel MX 15 270x45	112078

Výrobek	Číslo výrobku
Panel MX 15 270x45	112078
Panel MX 15 270x30	112090
Panel MXM 15 270x60	112849
Panel MX 15 120x240	112104
Panel MX 15 120x120	112143
Panel MX 15 120x90	112152
Panel MX 15 120x60	112221
Panel MX 15 120x45	112232
Panel MX 15 120x30	112239
Panel MXM 15 120x60	117915

PERI Nájemní kritéria

MAXIMO



Výrobek	Číslo výrobku
Panel MX 15 90x240	112115
Panel MX 15 90x90	112252
Panel MX 15 90x60	112259
Panel MX 15 90x45	112265
Panel MX 15 90x30	112271
Panel MX 15 60x240	112126
Panel MX 15 60x60	112280
Panel MX 15 60x45	112286
Panel MX 15 60x30	112292
Panel MX 15 30x240	112133

Výrobek	Číslo výrobku

PERI Nájemní kritéria

MAXIMO



Výrobek	Číslo výrobku
Panel MX 18, 330x240	124093
Panel MX 18, 330x120	124126
Panel MX 18, 330x90	124127
Panel MX 18, 330x60	124128
Panel MX 18, 330x45	124129
Panel MX 18, 330x30	124130
Panel MXM 18, 330x60	124163
Panel MX 18, 330x270	124131
Panel MX 18, 270x240	124132
Panel MX 18, 270x120	124134
Panel MX 18, 270x90	124138
Panel MX 18, 270x60	124135
Panel MX 18, 270x45	124136

Výrobek	Číslo výrobku
Panel MX 18, 270x30	124137
Panel MXM 18, 270x60	124188
Panel MX 18, 120x240	124139
Panel MX 18, 120x120	124142
Panel MX 18, 120x90	124143
Panel MX 18, 120x60	124144
Panel MX 18, 120x45	124145
Panel MX 18, 120x30	124146
Panel MXM 18, 120x60	124189

PERI Nájemní kritéria

MAXIMO



Výrobek	Číslo výrobku
Panel MX 18, 90x240	124147
Panel MX 18, 90x90	124148
Panel MX 18, 90x60	124149
Panel MX 18, 90x45	124150
Panel MX 18, 90x30	124151
Panel MX 18, 60x240	124157
Panel MX 18, 60x60	124158
Panel MX 18, 60x45	124160
Panel MX 18, 60x30	124159
Panel MX 18, 30x240	124162

Výrobek	Číslo výrobku













PERI Nájemní kritéria





















MAXIMO























Výrobek	Číslo výrobku
Vnější Roh MXA 120x35	112761
Vnější Roh MXA 120x45	112500
Vnější Roh MXA 270x35	112667
Vnější Roh MXA 270x45	112806
Vnější Roh MXA 330x35	114486
Vnější Roh MXA 330x45	114478
Vnější Roh MXA 60x35	112778
Vnější Roh MXA 60x45	112507
Vnější Roh MXA 90x35	126917
Vnější Roh MXA 90x45	126923
Vnitřní Roh MXI 330x60	114470
Vnitřní Roh MXI 330x50/20	115338
Vnitřní Roh MXI 270x60	112419

Výrobek	Číslo výrobku
Vnitřní Roh MXI 270x50/20	115255
Vnitřní Roh MXI 120x60	112689
Vnitřní Roh MX 120x50/20	115299
Vnitřní Roh MXI 90x60	112715
Vnitřní Roh MXI 90x50/20	115307
Vnitřní Roh MXI 60x60	112726
Vnitřní Roh MXI 60x50/20	115315
Šachtový roh MX 330	117913
Šachtový roh MX 270	117914
Šachtový roh MX 120	117915















Rám	Popis	Instrukce	Fakturace	Typ
	26.01 Vytržené části profilu a výztuhy	 		
	26.02 Poškozený čelní profil <ul style="list-style-type: none"> ■ promáčknutí způsobené sestavovacím hákem ■ poškození způsobené hrubým zacházením, zbytek rámu v dobrém stavu 	 Čelní profil  Čelní profil	 Tabulka (str. 18)  Tabulka (str. 18)	 

Rám	Popis	Instrukce	Fakturace	Typ
	26.03 Deformovaný podélný profil			
	<ul style="list-style-type: none"> ■ promáčknutí způsobené sestavovacím hákem ■ poškození způsobené hrubým zacházením 	   	 	 
	26.04 Díry v panelech			
	<ul style="list-style-type: none"> ■ ≤ Ø 3 cm 		 088028	
	<ul style="list-style-type: none"> ■ > Ø 3 cm v podélném profilu 	 		
<ul style="list-style-type: none"> ■ > Ø 3 cm v čelním profilu nebo žebrou 			Tabulka (str. 19) 	

Rám	Popis	Instrukce	Fakturace	Typ
	26.05 Promáčknuté žebro		 Tabulka (str. 19)	
	26.06 Poškozená nebo vytrhnutá lemovací vložka v žebro			
	<ul style="list-style-type: none"> ■ pokud je možné narovnění 		 088244	
	<ul style="list-style-type: none"> ■ pokud není možné narovnění 		Žebro  Tabulka (str. 19)	
<ul style="list-style-type: none"> ■ vytrhnutá lemovací vložka 		Žebro  Tabulka (str. 19)		

Rám	Popis	Instrukce	Fakturace	Typ
	26.07 Diagonálně ohnutý panel ■ > 6 mm			
	26.08 Ohnutý panel ■ > 8 mm			









Rám	Popis	Instrukce	Fakturace	Typ
	26.09 Vyboulený profil ■ ≤ 5 mm hloubka ■ > 5 mm hloubka	[✓] [spray] [wrench]	[no] 088027 [yes]	[eye] [gears]
	26.10 Vyboulená hrana profilu ■ ≤ 3 mm ■ > 3 mm a ≤ 10 mm ■ > 10 mm	[✓] [spray] [hammer] [wrench]	[no] 088236 [yes] 088236	[eye] [gears] [gears]









Rám	Popis	Instrukce	Fakturace	Typ
	26.11 Prasklina ve sváru rohu		 088028	
	26.12 Prasklina ve sváru na hraně profilu		 088028	
	<ul style="list-style-type: none"> ■ pokud je ohnutý profil 			
	<ul style="list-style-type: none"> ■ pokud není ohnutý profil 			

PERI Nájemní kritéria

MAXIMO



Rám	Popis	Instrukce	Fakturace	Typ
	26.13 Deformovaný odbedňovací roh nepoužitelný		 088056	
	26.14 Poškozená nebo chybějící lemovací vložka		 088002	

Rám	Popis	Instrukce	Fakturace	Typ
	<p>26.15 Díry v rámu způsobené zrezivěním</p> <ul style="list-style-type: none"> ■ Test s 300 g kladivem 	 		
	<p>26.16 Poškozený závit</p> <ul style="list-style-type: none"> ■ Test momentovým klíčem a 110 Nm 	 <p>125214</p>		

Roh	Popis	Instrukce	Fakturace	Typ
	26.17 Ohnutý roh v úhlu ■ > 10 mm			
	26.18 Ohnutý roh v úhlu ■ > 10 mm			

Výměnné těsnění MX (123603; 123604)	Popis	Instrukce	Fakturace	Typ
-------------------------------------	-------	-----------	-----------	-----

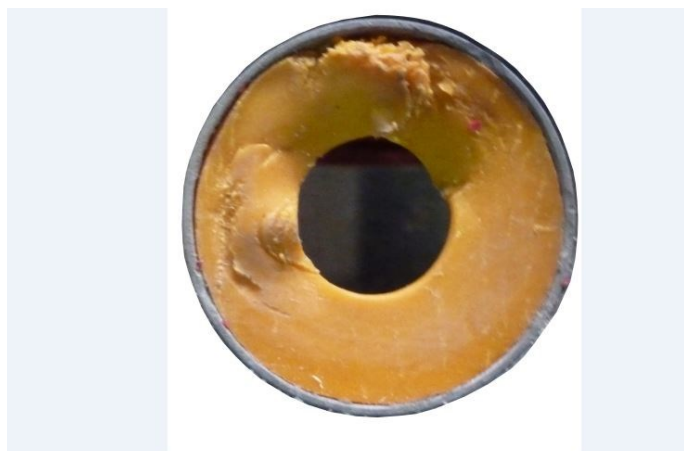

26.19 Poškozená pryžová vložka



088033



26.20 Znečištěná kotva



Poté namazat olejem PERI Clean



088073



PERI Nájemní kritéria

MAXIMO



Výrobek	Čelní profil	
	Náhradní díl	Číslo servisního artiklu
Čelní profil 30	109106	088049
Čelní profil 45	112065	088050
Čelní profil 60	109031	088051
Čelní profil 90	109023	088052
Čelní profil 120	109021	088053
Čelní profil 240	745051	088054
Čelní profil 270	745050	088055

PERI Nájemní kritéria

MAXIMO



Výrobek	Žebro	
	Náhradní díl	Číslo servisního artiklu
Žebro 18	745357	088038
Žebro 19	112479	088039
Žebro 22	745356	088040
Žebro 33	112511	088041
Žebro 34	112500	088042
Žebro 43	745355	088043
Žebro 48	745354	088044
Žebro 49	112508	088045
Žebro 78	745352	088046
Žebro 122	745350	088047
Žebro 140	116461	088048
Žebro 108	745351	088230
Žebro 60	745353	088232

MAXIMO Kloubový roh

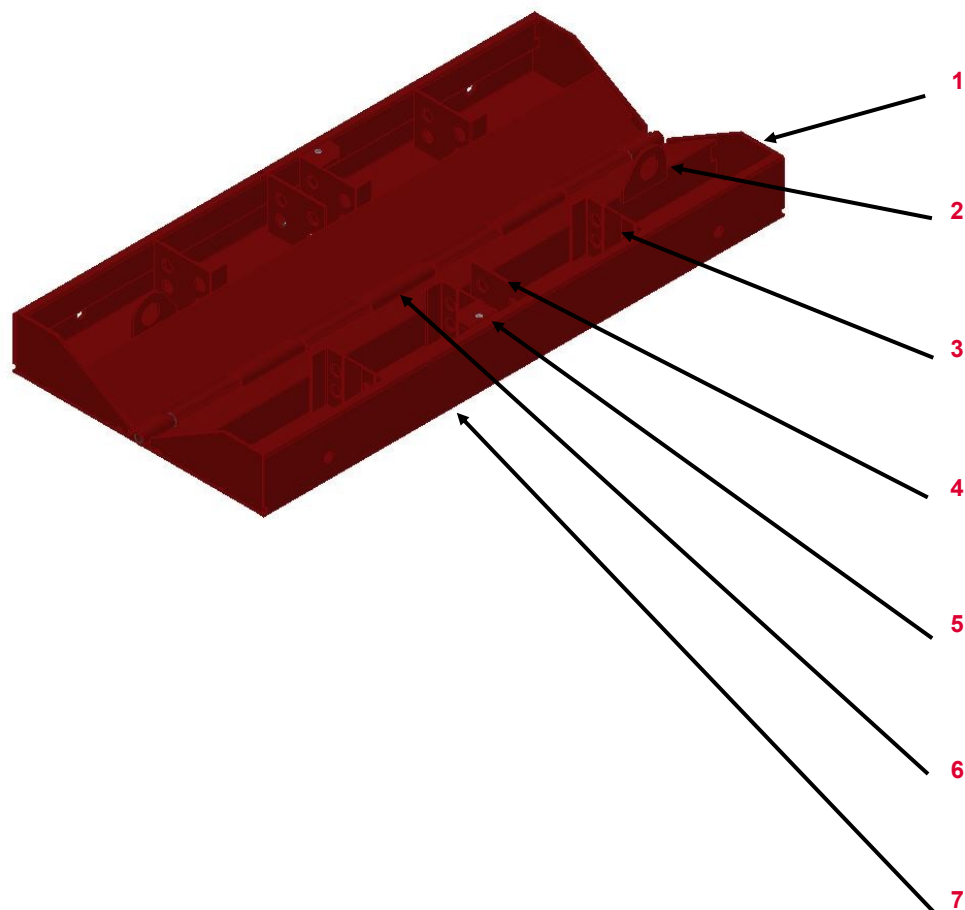

Č.	Popis	Číslo výrobku
1	Čelní deska	111751
2	Montážní oko	111709
3	„Žebrový profil“	111708
4	Nosný plech	114105
5	„Závitové očko“	113210
6	Kloub	
7	Plocha k betonu	
Platné pro		Číslo výrobku
Kloubový roh MXGA 120		111850
Kloubový roh MXGA 270		111872
Kloubový roh MXGA 330		114607
Kloubový roh MXGI 120		113246
Kloubový roh MXGI 270		113203
Kloubový roh MXGI 330		114550
Kloubový roh MXGI 18 120		124201
Kloubový roh MXGI 18 270		124200
Kloubový roh MXGI 18 330		124202

Kloubový roh	Popis	Instrukce	Fakturace	Typ
--------------	-------	-----------	-----------	-----



26.21 Promáčknutí nebo zlomení profilu nebo plochy k betonu

■ ≤ 3 mm



■ > 3 mm











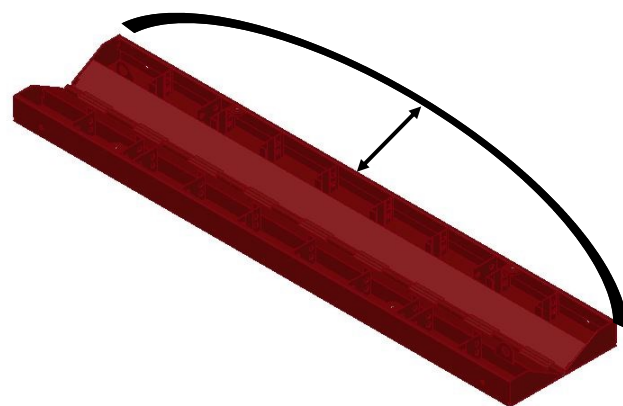











088027



26.22 Ohnutý rám

■ > 8 mm



Kloubový roh	Popis	Instrukce	Fakturace	Typ
	26.23 Ohnutý nosný plech nebo “Žebrový profil”			
	<ul style="list-style-type: none"> ■ roh lze zavřít obtížně 			
	<ul style="list-style-type: none"> ■ roh nelze zavřít 			
	<ul style="list-style-type: none"> ■ poškozený svár 			
	26.24 Ohnuté montážní oko			
	<ul style="list-style-type: none"> ■ roh lze zavřít obtížně 			
	<ul style="list-style-type: none"> ■ roh nelze zavřít 			
	<ul style="list-style-type: none"> ■ poškozený svár 			

Kloubový roh	Popis	Instrukce	Fakturace	Typ
	26.25 Kotvící deska			
	■ Ohnutá		088244	
	■ poškozený svár			
	■ vytržená			
	26.26 Deformovaná nebo vytržená čelní deska			
	■ > 3 mm		088244	
	■ roh nelze zavřít	111842 (MXGA) 111751 (MXGI)		

Kloubový roh	Popis	Instrukce	Fakturace	Typ
--------------	-------	-----------	-----------	-----

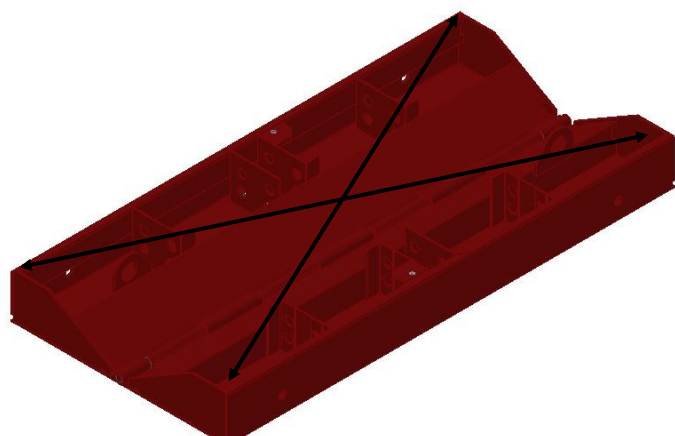
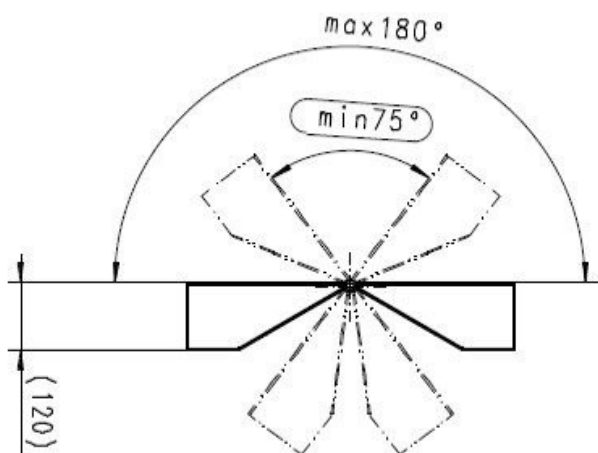

26.27 Funkce

- roh lze zavřít obtížně
- roh nelze zavřít
- Nefunkční roh po čištění a opravě



Poté kloub nastříkejte olejem



26.28 Diagonálně ohnutý rám

- > 5 mm



PERI Nájemní kritéria

MAXIMO





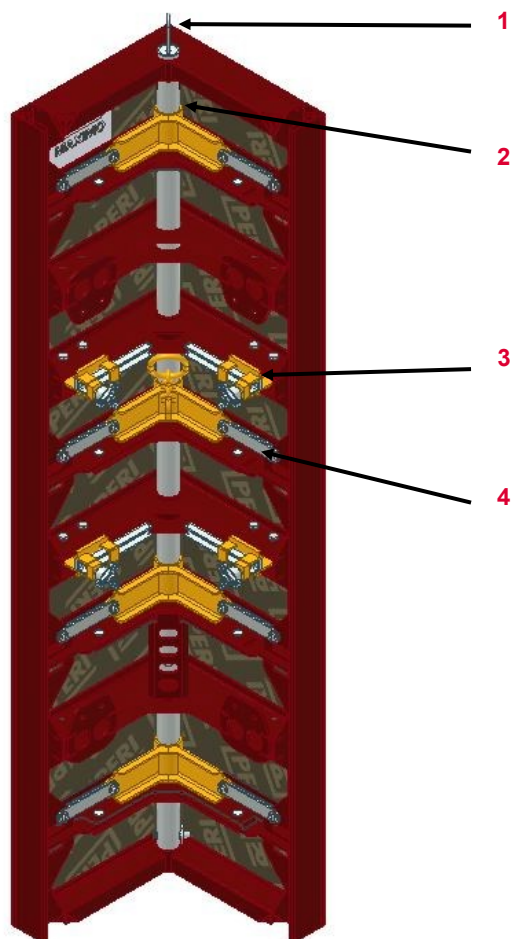









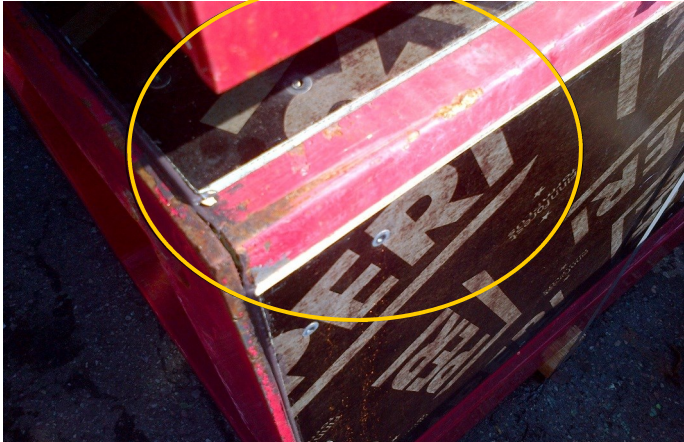





MAXIMO Šachtový roh MX



Č.	Popis	Číslo výrobku
1	Odbedňovací oko	118140
2	Táhlo	118182
3	Poziční římsa	126263
4	Odbedňovací páka MX	118136

Platné pro	Číslo výrobku
Šachtový roh MX 120	117915
Šachtový roh MX 270	117914
Šachtový roh MX 330	117913
Šachtový roh MX 18, 120	125288
Šachtový roh MX 18, 270	125286
Šachtový roh MX 18, 330	125284

Šachtový roh	Popis	Instrukce	Fakturace	Typ	
	26.29 Poškozený rám a žebro v důsledku obtížného demontování				
	26.30 Vyčnívající překližka z profilu		Odstranění nebo nastavení hliníkového proužku, tak že profil a překližka jsou vyrovnány		

Šachtový roh	Popis	Instrukce	Fakturace	Typ		
	26.31 Prasklina ve sváru táhla			088061		
	26.32 Odbedňovací páka MX ohnutá	<ul style="list-style-type: none"> ■ odbedňovací páka je funkční 			088244	
	<ul style="list-style-type: none"> ■ odbedňovací páka není funkční 		118136 (páka)		088067	

Šachtový roh	Popis	Instrukce	Fakturace	Typ
--------------	-------	-----------	-----------	-----

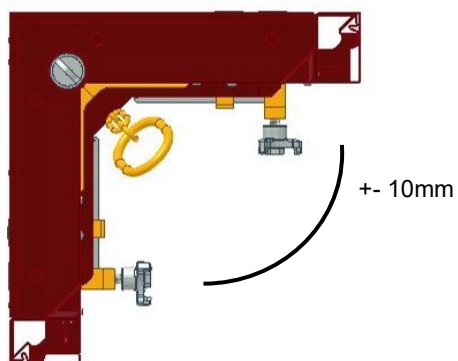

26.33 Ohnutý rám

- > 10 mm

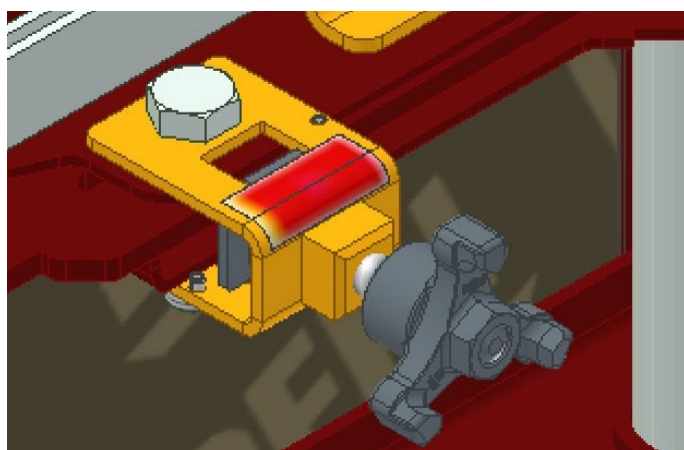

Aretace pro MXSE -2

- Chybí
- Poškozeno silou



131439



131439

















088060



088060



Šachtový roh	Popis	Instrukce	Fakturace	Typ
	Upínací držák			
	<ul style="list-style-type: none"> ■ Chybí 			
	<ul style="list-style-type: none"> ■ Poškozeno silou 			
	Ohnutý boční profil			
	<ul style="list-style-type: none"> ■ Lze narovnat 			
	<ul style="list-style-type: none"> ■ Nelze narovnat 			

Šachtový roh, poškození překližek	Popis	Instrukce	Fakturace	Typ
	Rýhy			
	<ul style="list-style-type: none"> ■ Povrchové (Není vidět hliník) 	 Zarovnání škrabkou		
<ul style="list-style-type: none"> ■ Hluboké rýhy (Viditelný hliník) 	 WI_37_Alkus_Plywood_1511_en			
	Škrábance			
	<ul style="list-style-type: none"> ■ Šířka < 3 mm 	 Zarovnání škrabkou		
<ul style="list-style-type: none"> ■ Šířka > 3 mm 	 WI_37_Alkus_Plywood_1511_en			

Šachtový roh—poškození překližek	Popis	Instrukce	Fakturace	Typ
----------------------------------	-------	-----------	-----------	-----

















■ Velké poškození překližky



Výměna desky



Šachtový roh—plastová překližka	Popis	Instrukce	Fakturace	Typ
	Díry			
	<ul style="list-style-type: none"> ■ < Ø 3mm 	 Zarovnání škrabkou		
	<ul style="list-style-type: none"> ■ > Ø 3 mm 	 WI_37_Alkus_Plywood_1511_en		
	<ul style="list-style-type: none"> ■ > Ø 22 mm 	 Výmena překližky		
	Poškozená vrstva Pactanu			

Vnější Rohový Profil(135447 135444 135441) Popis	Instrukce	Fakturace	Typ
--	-----------	-----------	-----

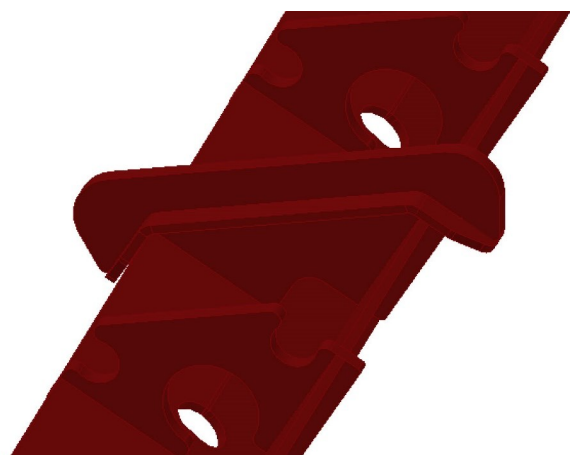

Ohnuté části

■ Lze narovnat



■ Nelze narovnat

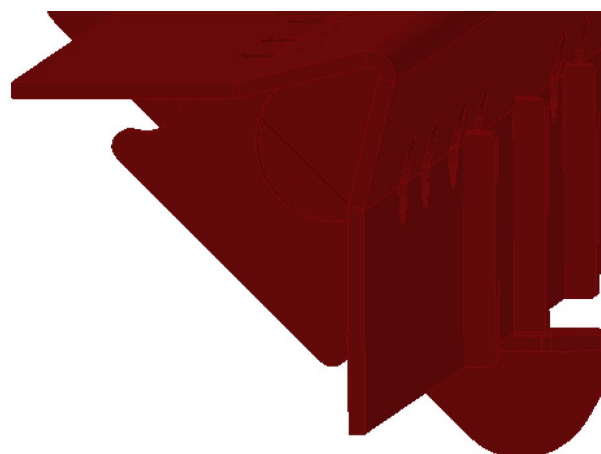

Ohnutý profil

■ Lze narovnat



■ Nelze narovnat



PERI Nájemní kritéria

MAXIMO





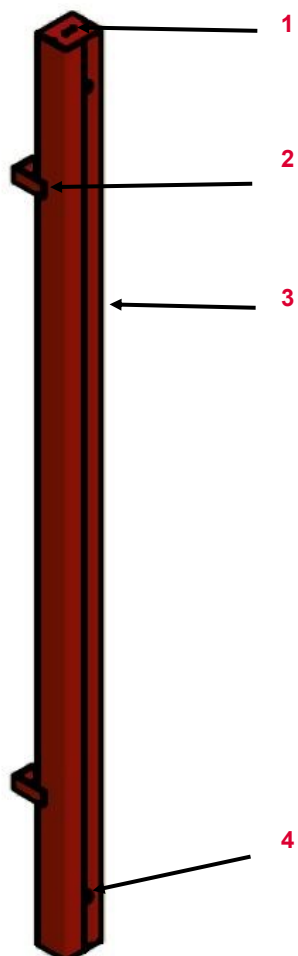





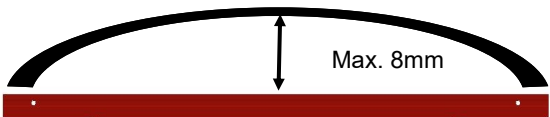

Vložka WDA Alu.	Č.	Popis	Číslo výrobku
-----------------	----	-------	---------------

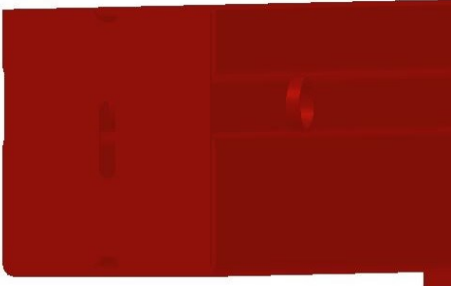









1	Čelní plech	101959
2	Háček	
3	Plocha k betonu	
4	Lemovací vložka	





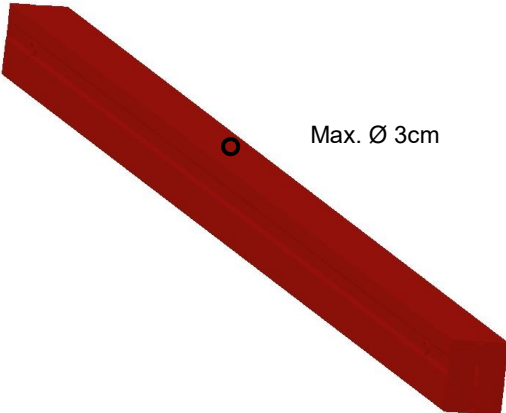

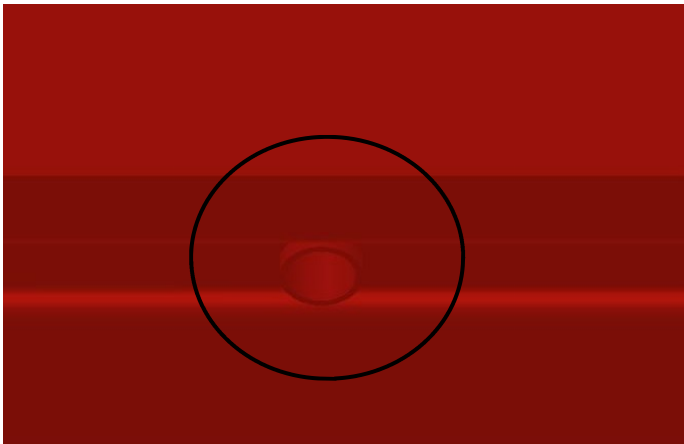

Platné pro	Číslo výrobku
Vložka WDA MX 120x10 Alu	114142
Vložka WDA MX 270x10 Alu	114128
Vložka WDA MX 330x10 Alu	114394

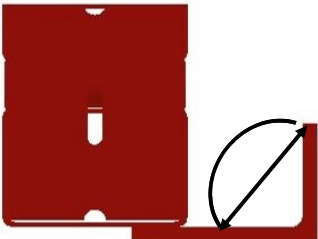
Vložka WDA alu.	Popis	Instrukce	Fakturace	Typ
	<p>26.34 Ohnutá vložka</p> <ul style="list-style-type: none"> ■ > 8 mm 			
	<p>26.35 Promáčknutí v ploše k betonu</p> <ul style="list-style-type: none"> ■ ≤ 3 mm ■ > 3 mm < 10 mm ■ > 10 mm 	<ul style="list-style-type: none"> 	<ul style="list-style-type: none"> 088244 	<ul style="list-style-type: none">

Vložka WDA alu.	Popis	Instrukce	Fakturace	Typ
	26.36 Deformovaný čelní plech (bez poškození sváru)			
	26.37 Deformovaný čelní plech (s poškozením sváru)		 088001	

Vložka WDA	Popis	Instrukce	Fakturace	Typ
	Koncový profil (polyamid verze)	 135968 (Koncový profil)		
	<ul style="list-style-type: none"> ■ Chybí 	 135968 (Koncový profil)		
	<ul style="list-style-type: none"> ■ Poškozeno silou 			

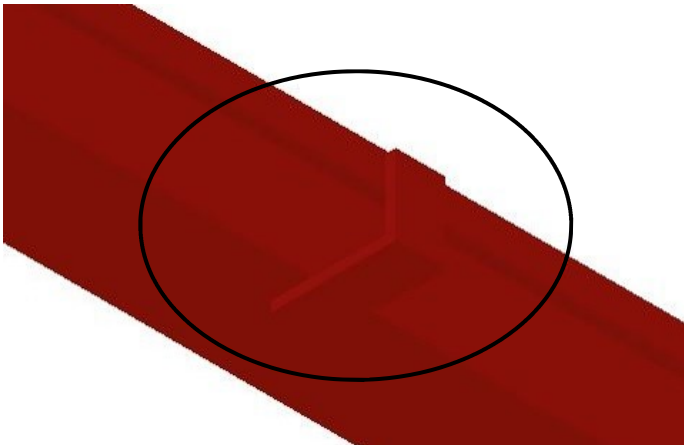
Vložka WDA alu.	Popis	Instrukce	Fakturace	Typ
	26.38 Díra v ploše k betonu <ul style="list-style-type: none"> ■ $\varnothing \leq 3 \text{ cm}$ ■ $\varnothing > 3 \text{ cm}$ 	 	 088028 	 
	26.39 Poškozená / nepoužitelná trubička			





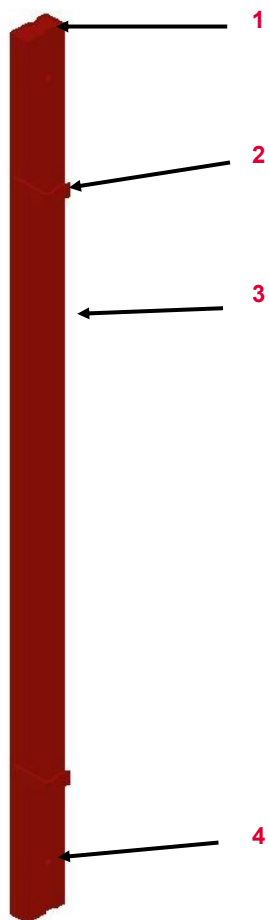



Vložka WDA alu.	Popis	Instrukce	Fakturace	Typ	
	26.40 Ohnutý háček				
	■ ≤ 10 mm			088244	
	■ > 10 mm			088000	
	26.41 Chybějící háček				
				740781 (WDA 120) 740776 (WDA 270 + 330)	088000

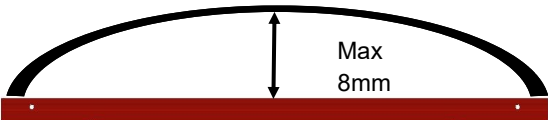

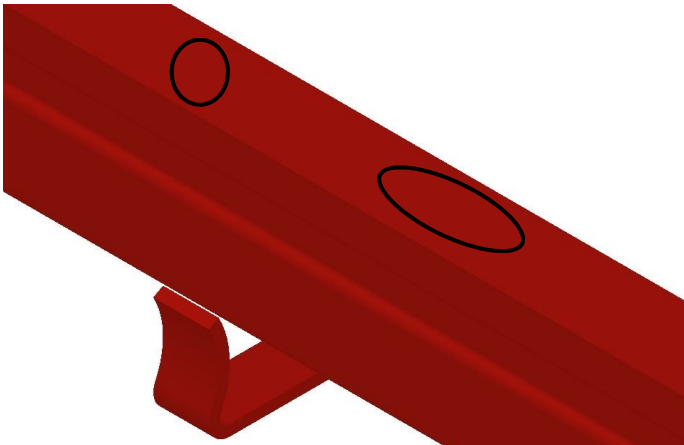





MX Vložka WDA ocel.











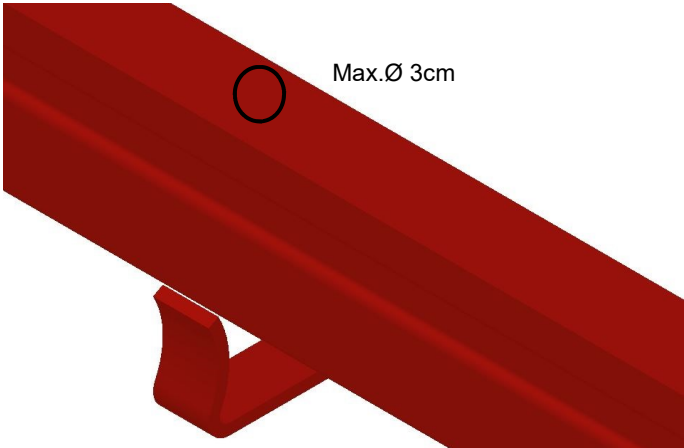



Č.	Popis	Číslo výrobku
1	Čelní plech	
2	Profile	
3	Plocha k betonu	
4	Lemovací vložka	

Platné pro	Číslo výrobku
Vložka WDA WDA MX 330x6	114846
Vložka WDA WDA MX 330x5	114826
Vložka WDA WDA MX 330x4	114842
Vložka WDA WDA MX 270x6	114174
Vložka WDA WDA MX 270x5	114186
Vložka WDA WDA MX 270x4	114165
Vložka WDA WDA MX 120x6	114181
Vložka WDA WDA MX 120x5	114191
Vložka WDA WDA MX 120x4	114212

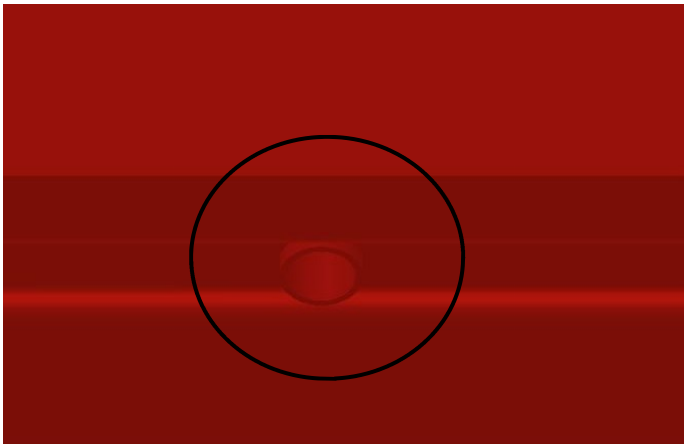
Vložka WDA ocel.	Popis	Instrukce	Fakturace	Typ	
	26.42 Ohnutá vložka	<ul style="list-style-type: none"> ■ > 8 mm 			
	26.43 Promáčknutí v ploše k betonu	<ul style="list-style-type: none"> ■ ≤ 3 mm 			
		<ul style="list-style-type: none"> ■ > 3 mm ≤ 10 mm 			
		<ul style="list-style-type: none"> ■ > 10 mm 			

Vložka WDA ocel.	Popis	Instrukce	Fakturace	Typ	
	26.44 Deformovaný čelní plech (bez poškození sváru)				
	26.45 Deformovaný čelní plech (s poškozením sváru)			088001	

Vložka WDA ocel.	Popis	Instrukce	Fakturace	Typ
	<p>26.46 Díry v ploše k betonu</p> <ul style="list-style-type: none"> ■ $\varnothing \leq 3 \text{ cm}$ ■ $\varnothing > 3 \text{ cm}$ 	<p>    </p>	<p>  088028  </p>	<p>   </p>
	<p>26.47 Lemovací vložka poškozená/ nepoužitelná</p>	<p></p>	<p></p>	<p></p>

Vložka WDA ocel.	Popis	Instrukce	Fakturace	Typ
------------------	-------	-----------	-----------	-----

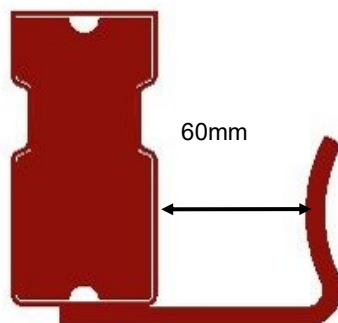

Ohnutý háček

■ ≤ 10 mm



088244



■ Or > 10 mm



088164



Chybějící nebo prasklý háček











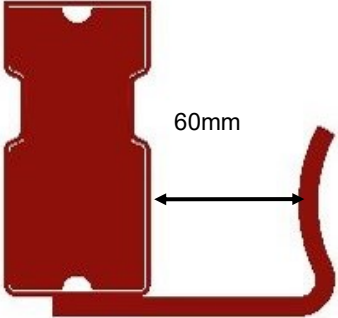





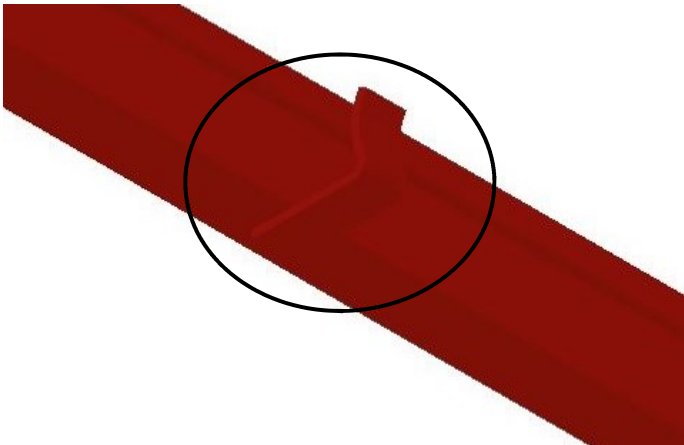











WI_24_10_DOMINO_DWD_profile_1
410_en

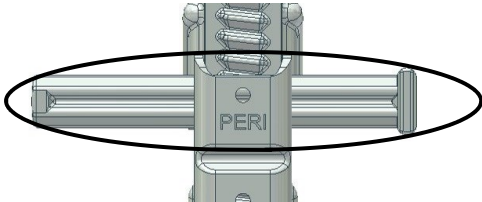

088164

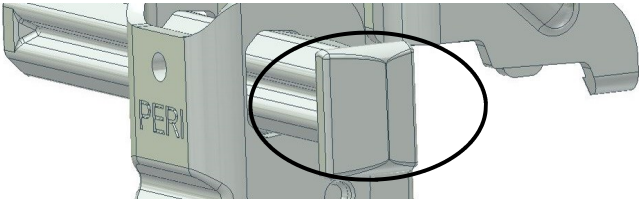

Vložka WDA ocel.	Popis	Instrukce	Fakturace	Typ
	<p>26.48 Ohnutý háček</p> <ul style="list-style-type: none"> ■ ≤ 10 mm ■ > 10 mm 	<ul style="list-style-type: none">   	<ul style="list-style-type: none">  088244  088164 	<ul style="list-style-type: none">  
	<p>26.49 Chybějící háček</p>	<ul style="list-style-type: none">  	<ul style="list-style-type: none">  088164 	<ul style="list-style-type: none"> 





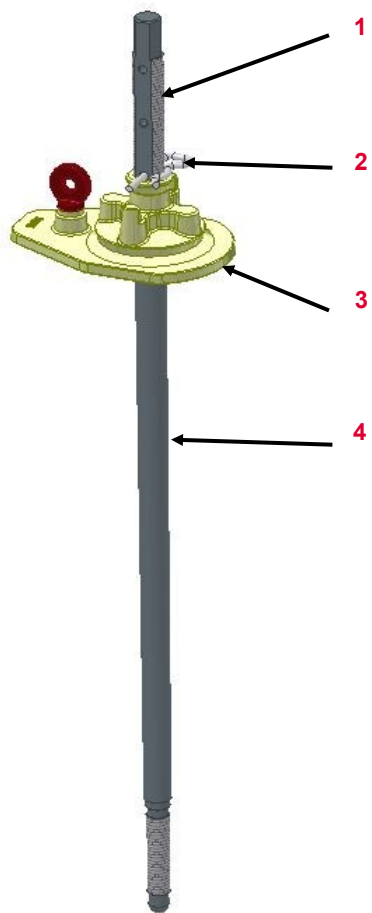







Zámek BFD (023500)	Popis	Instrukce	Fakturace	Typ
	26.62 Ohnutá čelist		 088244	
	26.63 Rozebraný zámek		 088032	
	26.64 Klín je nefunkční — ohnutý nebo prasknutý			
	26.65 Prasklá hlava klínu			

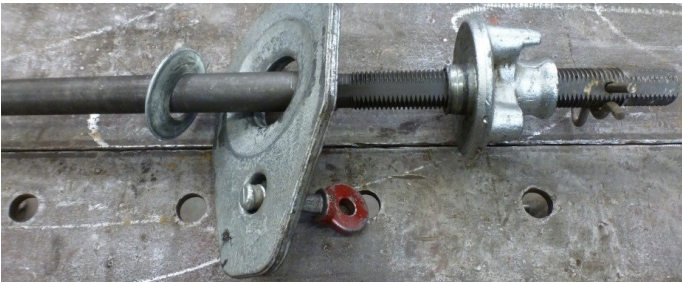







MAXIMO Spínací tyč	Č.	Popis	Číslo výrobku
--------------------	----	-------	---------------











1	Závit	
2	Závlačka MX	113256
3	Kotevní plech s maticí	123910
4	Kotevní táhlo	

Platné pro	Číslo výrobku
Spínací tyč MX 15-25	113847
Spínací tyč MX 20-30	112387
Spínací tyč MX 30-40	112464
Spínací tyč MX 15-25	123901
Spínací tyč MX 20-30	123902
Spínací tyč MX 30-40	123903
Spínací tyč MX 40-50	123904
Spínací tyč MX 50-60	123905

MAXIMO Spínací tyč	Popis	Instrukce	Fakturace	Typ
	26.66 Znečištěný závit		 088075	
	26.67 Uvolněné díly		 088075	
	26.68 Poškozený závit		 088075	









MX Kloubová matice (112386, 123900)	Popis	Instrukce	Fakturace	Typ
	26.69 Deformovaný / chybějící kolík			
	26.70 Deformovaná lemovací vložka			









Klíč táhla MX15 (116841)	Popis	Instrukce	Fakturace	Typ
	<p>26.71 Šestihránná vložka vypadává (Klíč táhla 2. generace)</p>			
	<p>26.72 Šestihránná vložka prokluzuje při utahování, protože je namazána olejem nebo mazivem (Klíč táhla 2. generace)</p>	 Demontujte šestihránnou vložku a třecí plochy důkladně vyčistěte a odmastěte		
	<p>26.73 Poškozená pružina</p>			

PERI Nájemní kritéria

MAXIMO

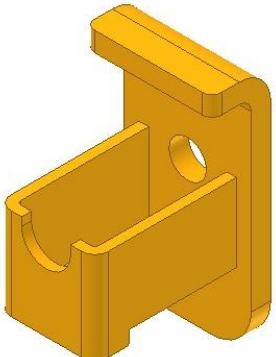

MAR (124941; 124942)	Popis	Instrukce	Fakturace	Typ
	26.76 Ohnutý dvojitý hák		 088035	
	26.77 Zlomený dvojitý hák		 088035	

MAR (124941; 124942)	Popis	Instrukce	Fakturace	Typ
	26.78 Promáčkнутý profil		 088244	
	26.79 Deformovaný posuvný vodič		 088076	

PERI Nájemní kritéria

MAXIMO



Hlava Stabilizátoru MX/TR (023660)	Popis	Instrukce	Fakturace	Typ		
	Prasklý svár					
	Ohnuté části			088244		
	Prasklá matice		030190 (trojkřídlá matice)		088541	

PERI Nájemní kritéria

MAXIMO



Vzpěra MX (123842; 115350)

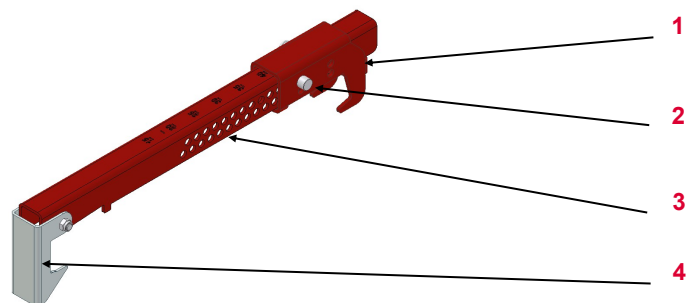

Č.	Popis	Číslo výrobku
1	„Botka“	115349
2	Šroub D=12	115331
3	„Závora“	123841
4	„Pojistný hák“	114390

Vzpěra MX

Popis	Instrukce	Fakturace	Typ
-------	-----------	-----------	-----



26.50 Ohnutá botka



088244

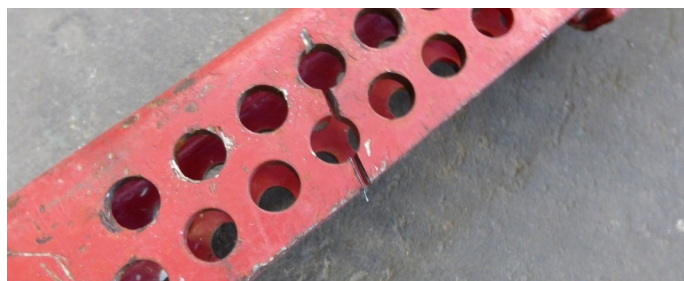

26.84 Prořezané otvory v závoře



PERI Nájemní kritéria

MAXIMO



Přestavovací konzola MX/TR (101633)	Popis	Instrukce	Fakturace	Typ
-------------------------------------	-------	-----------	-----------	-----

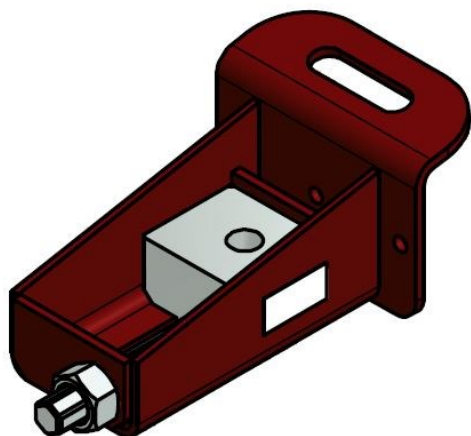

Ohnuté části



088244



Znečištěný závit











Nutná kontrola funkčnosti

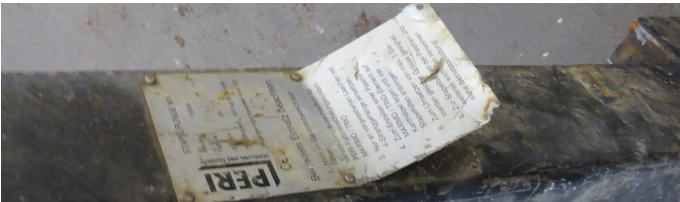

PERI Nájemní kritéria

MAXIMO



Paletová příloška Maximo (115058)	Popis	Instrukce	Fakturace	Typ
	26.87 Ohnutý profil		 088244	
	26.88 Prasklina ve sváru	 		
	26.89 Nečitelný, chybějící štítek		 088037	
	26.90 Ohnuté prvky		 088244	

Těsnící kónus (112937; 127425)

Popis

Instrukce

Fakturace

Typ

26.91 Poškození kónusu



26.92 Znečištění od betonu



Poté namažte olejem PERI Clean

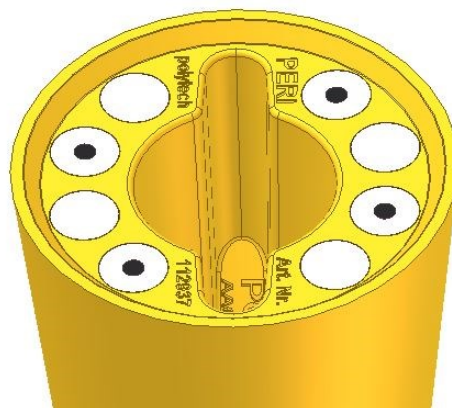

Magnetický kónusový klíč (126696)	Popis	Instrukce	Fakturace	Typ
-----------------------------------	-------	-----------	-----------	-----

26.93 Ohnutý jazyk

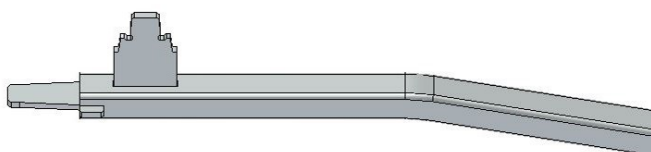

26.94 Ohnutá hlava klíče



088244

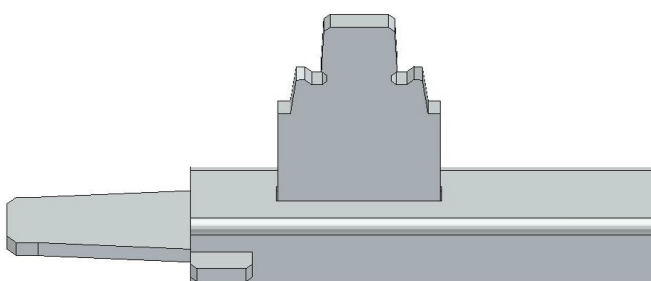

PERI Nájemní kritéria







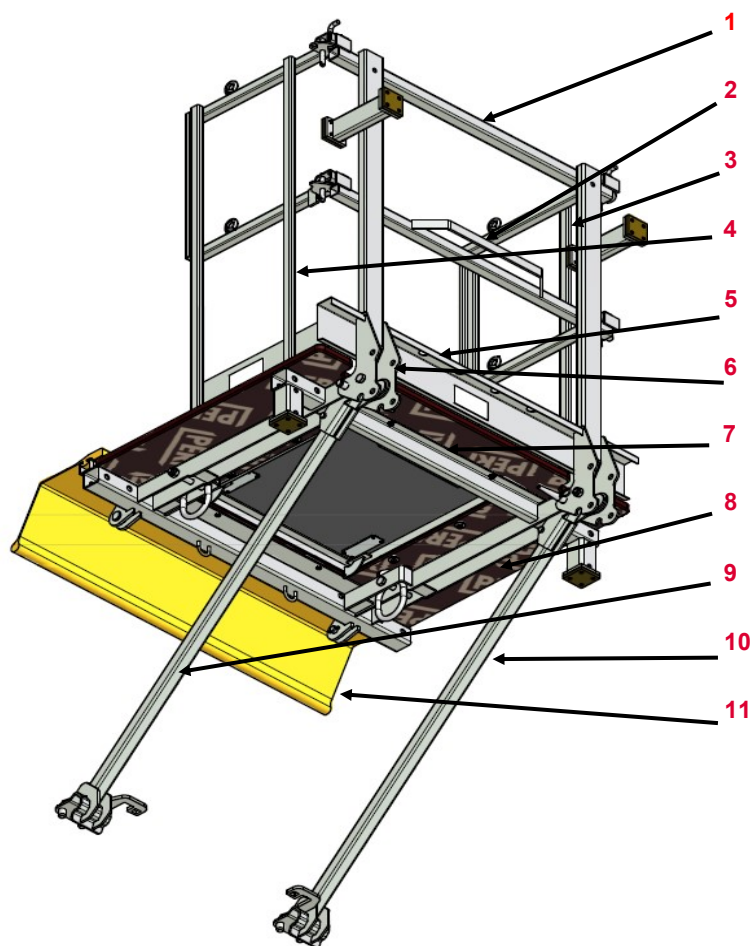

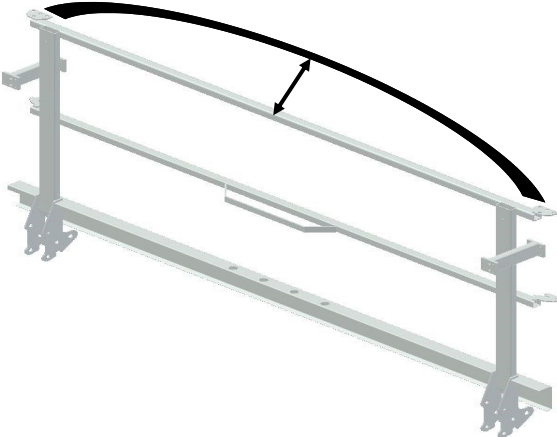

MAXIMO



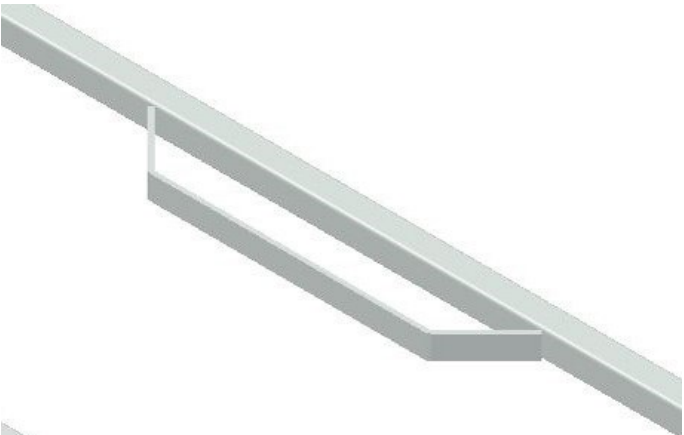







Plošina MXP (115939; 115940)











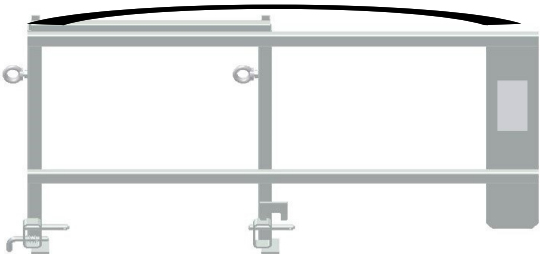



Č.	Popis	Číslo výrobku MXP 90	Číslo výrobku MXP 72
1	Ochranné Zábradlí	116171	116402
2	Konzola	116349	116349
3	Boční Zábradlí pravé	115946	115946
4	Boční Zábradlí levé	115945	115945
5	Okopová deska	116169	116399
6	Styčnick	116618	116618
7	Konzola plošiny	116160	116396
8	Deska MXP s otvorem	116080	116105
9	Podpěra levá	116012	116012
10	Podpěra pravá	116015	116015
11	Pryžový kryt proti prachu	114600	116390

Plošina MXP	Popis	Instrukce	Fakturace	Typ
	26.95 Zábradlí ohnuté	 		
	<ul style="list-style-type: none"> ■ ≤ 5 mm 			
<ul style="list-style-type: none"> ■ > 5 mm 				
26.96 Konzola ohnutá				
<ul style="list-style-type: none"> ■ S prasklinou ve sváru 				

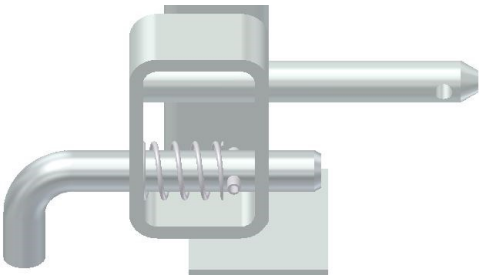
Plošina	Popis	Instrukce	Fakturace	Typ
	26.97 Okopová deska ohnutá		 088244	
	26.98 Zdeformované otvory v okopové desce	 116399 (120x100) 116169 (240x100)		







Plošina MXP	Popis	Instrukce	Fakturace	Typ
	26.99 „Styčnick“ ohnutý			
	■ ≤ 5 mm	088244		
	■ > 5 mm	116618		

Plošina MXP	Popis	Instrukce	Fakturace	Typ
	26.100 Boční zábradlí ohnuté ■ > 5 mm			
	26.101 Ohnutá výztuha	 116050		
	26.102 Poškozený/ chybějící čep	 117956 (šroub) 114288 (pružina) 722930 (pružinový kolík)	 088192	







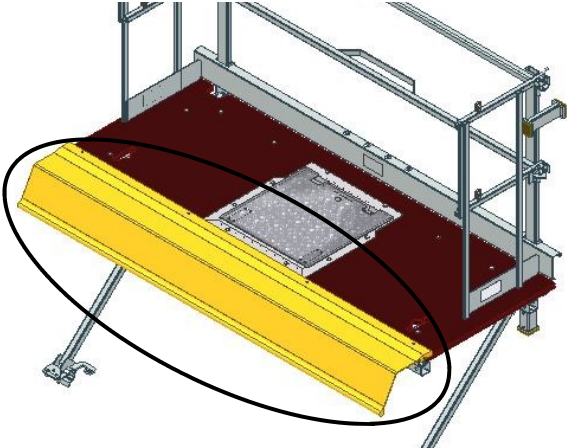

PERI Nájemní kritéria

MAXIMO



Plošina MXP	Popis	Instrukce	Fakturace	Typ
	26.103 Opotřebovaná podlaha	 116080 (240x100) 116105 (120x100)	 088079 088080	
	26.104 Podlaha poškozená hrubým zacházením	 116080 (240x100) 116105 (120x100)	 088079 088080	

Plošina MXP	Popis	Instrukce	Fakturace	Typ
	26. 105 Funkčnost poklopu není možná z důvodu poškození hrubým zacházením	 115141	 088099	

Plošina MXP	Popis	Instrukce	Fakturace	Typ
	<p>26.106 Pryžový kryt proti prachu uříznutý, vytržený</p>	 <p>114600 (240x100) 116390 (120x100)</p>	 <p>088095 088094</p>	
	<p>26.107 Podpěra ohnutá</p> <p>■ > 5 mm</p>	 <p>116015 (pravá) 116012 (levá)</p>	 <p>088089</p>	

PERI Nájemní kritéria







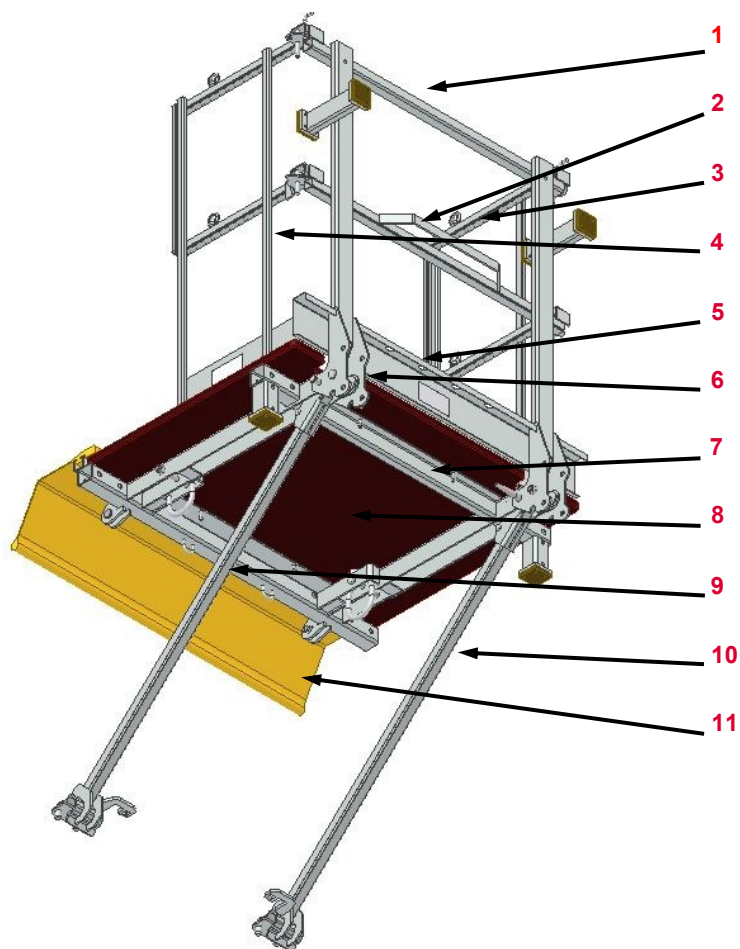

MAXIMO

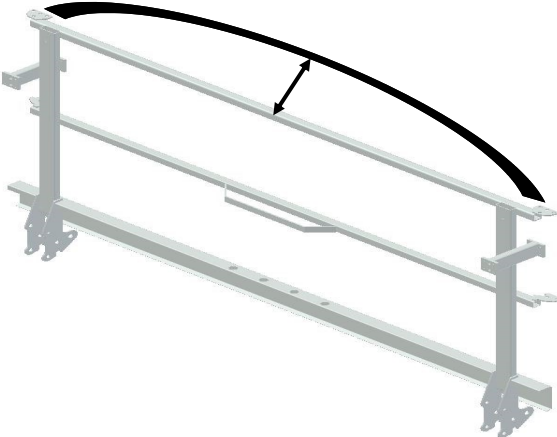









Plošina MXP











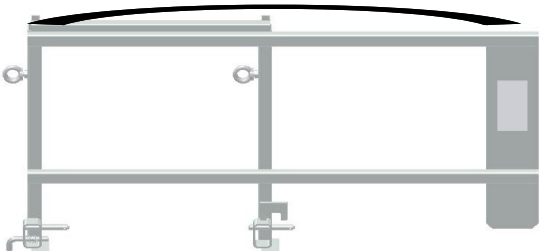



Č.	Popis	Číslo výrobku	Číslo výrobku
1	Zábradlí	116171	116402
2	Konzola	116349	116349
3	Boční zábradlí pravé	115946	115946
4	Boční zábradlí levé	115945	115945
5	Okopová deska	116169	116399
6	„Styčnick“	116618	116618
7	Konzola plošiny	116160	116396
8	Deska MXP bez otvoru	116088	116089
9	Podpěra levá	116012	116012
10	Podpěra pravá	116015	116015
11	Pryžový kryt proti prachu	114600	116390

Plošina MXP	Popis	Instrukce	Fakturace	Typ
	26.108 Zábradlí ohnuté	 		
	<ul style="list-style-type: none"> ■ ≤ 5 mm 			
<ul style="list-style-type: none"> ■ > 5 mm 				
26.109 Konzola ohnutá				
<ul style="list-style-type: none"> ■ S prasklinou ve sváru 				

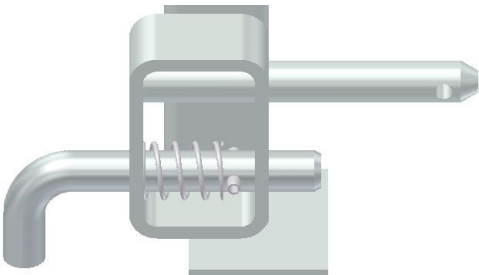







Plošina MXP	Popis	Instrukce	Fakturace	Typ
	26.110 Okopová deska ohnutá		 088244	
	26.111 Zdeformované otvory v okopové desce	 116399 (120x100) 116169 (240x100)		

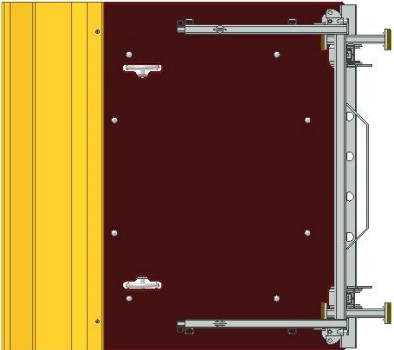



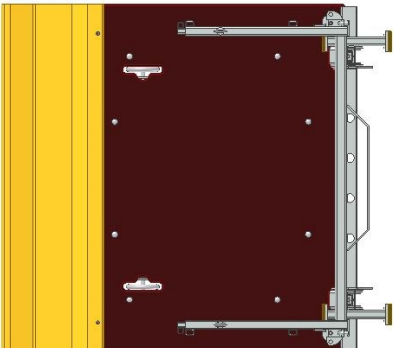

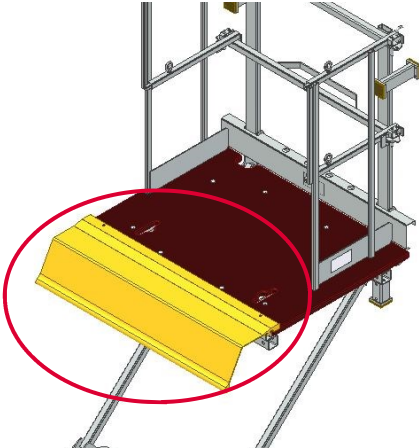

Plošina MXP	Popis	Instrukce	Fakturace	Typ
	26.112 „Styčnik“ ohnutý			
	■ ≤ 5 mm			
	■ > 5 mm	116618	088244	

Plošina MXP	Popis	Instrukce	Fakturace	Typ
	26.113 Boční zábradlí ohnuté ■ > 5 mm			
	26.114 Okopová deska ohnutá	 116050		
	26.115 Poškozený/ chybějící čep	 117956 (šroub) 114288 (pružina) 722930 (pružinový kolík)	 088192	

PERI Nájemní kritéria MAXIMO



Plošina MXP	Popis	Instrukce	Fakturace	Typ
	26.116 Opotřebovaná podlaha	 116088 (240x100) 116089 (120x100)		
	26.117 Podlaha poškozená hrubým zacházením	 116088 (240x100) 116089 (120x100)	 088082 088078	

Plošina MXP	Popis	Instrukce	Fakturace	Typ
	<p>26.118 Pryžový kryt proti prachu uříznutý, vytržený</p>	 <p>114600 (240x100) 116390 (120x100)</p>	 <p>088095 088094</p>	
	<p>26.119 Podpěra ohnutá</p> <p>■ > 5 mm</p>		 <p>088089</p>	

Plošina MXP

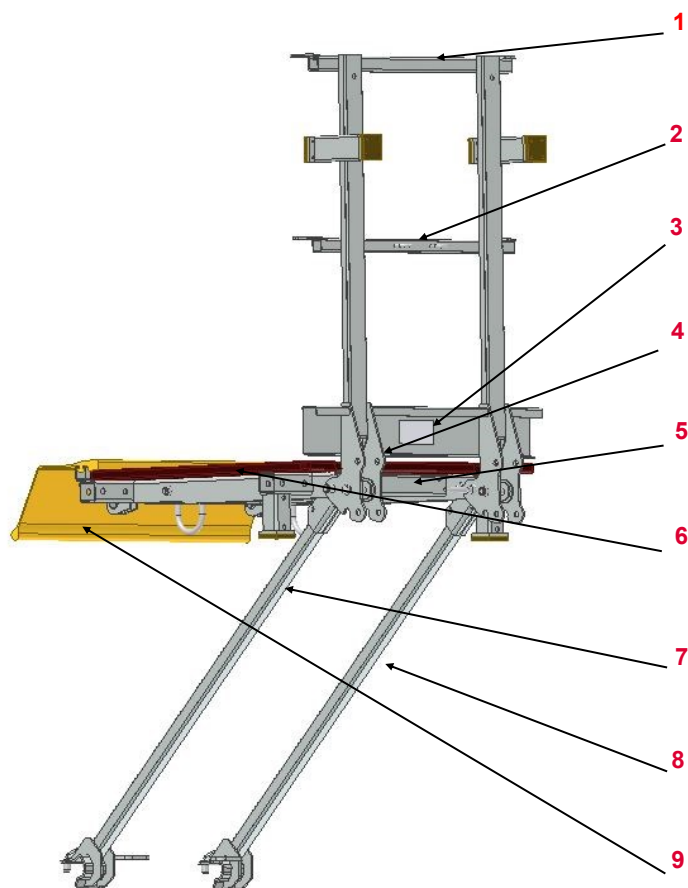

Č.	Popis	Číslo výrobku	Číslo výrobku
1	Zábradlí	116244	116558
2	Spodní zábradlí		
3	Okopová deska	116242	116556
4	„Styčnick“	116618	116618
5	Konzola plošiny	116239	116553
6	Deska MXP	116245	116559
7	Podpěra levá	116012	116012
8	Podpěra pravá	116015	116015
9	Pryžový kryt proti prachu	116091	116547

Plošina MXP	Popis	Instrukce	Fakturace	Typ
-------------	-------	-----------	-----------	-----

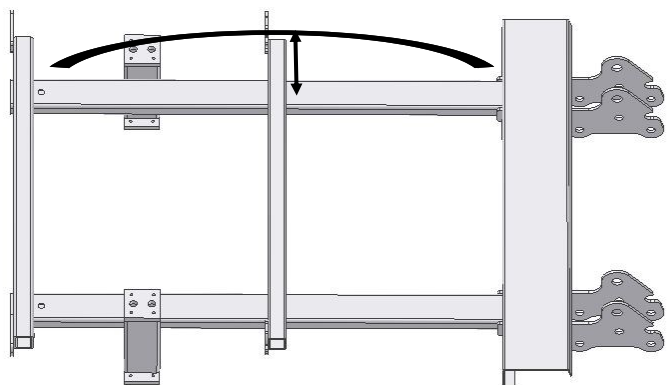

26.120 Zábradlí ohnuté

■ ≤ 5 mm



■ > 5 mm



116244 (MXP 90)
116658 (MXP 72)



088084
088087

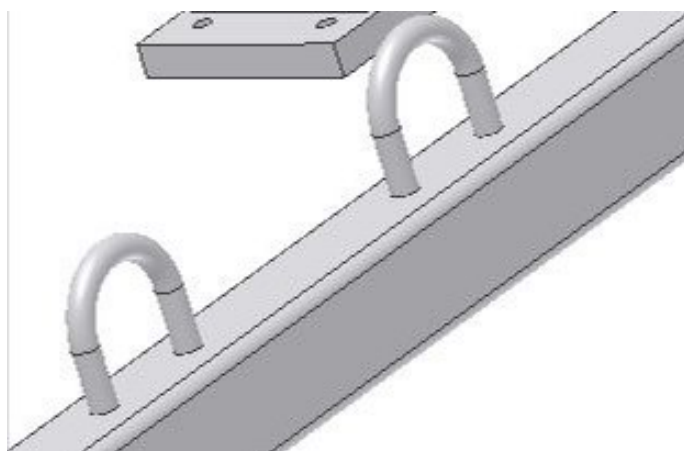

26.121 Spodní zábradlí ohnuté

■ Bez praskliny ve sváru











088244



■ S prasklinou ve sváru











Plošina MXP	Popis	Instrukce	Fakturace	Typ	
	26.122 Okopová deska ohnutá		 088244		
	26.123 Zdeformované otvory v okopové desce		116242 (90x100) 116556 (72x100)		

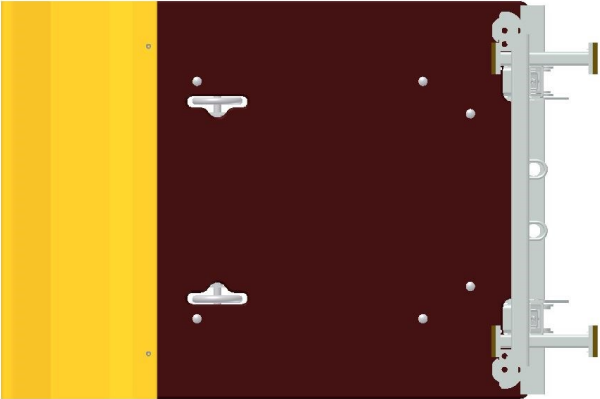



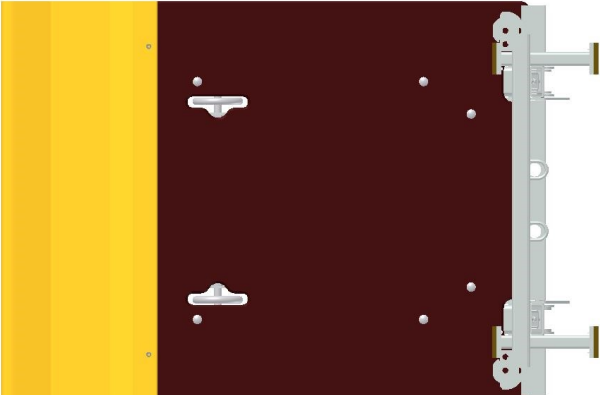

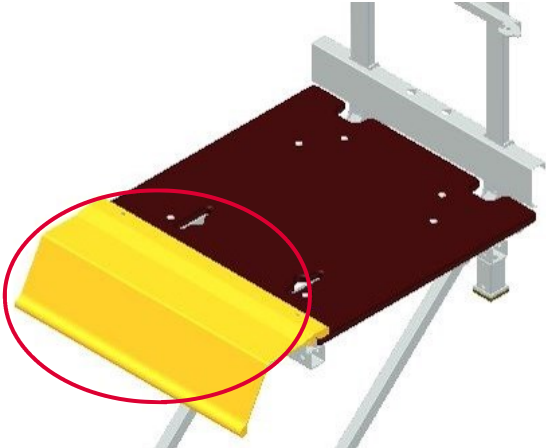

Plošina MXP	Popis	Instrukce	Fakturace	Typ
	26.124 „Styčnik“ ohnutý	<ul style="list-style-type: none"> ■ ≤ 5 mm 		
	<ul style="list-style-type: none"> ■ > 5 mm 		116618	

PERI Nájemní kritéria

MAXIMO



Plošina MXP	Popis	Instrukce	Fakturace	Typ
	26.125 Opotřebovaná podlaha	 116245 (90x100) 116559 (72x100)		
	26.126 Podlaha poškozená hrubým zacházením	 116245 (90x100) 116559 (72x100)	 088077 088081	

Plošina MXP	Popis	Instrukce	Fakturace	Typ
	<p>26.127 Pryžový kryt proti prachu uříznutý, vytržený</p>	 <p>116091 (90x100) 116547 (72x100)</p>	 <p>088093 088096</p>	
	<p>26.128 Podpěra ohnutá</p> <p>■ > 5 mm</p>	 <p>116012 (levá) 116015 (pravá)</p>	 <p>088089</p>	

PERI Nájemní kritéria

MAXIMO





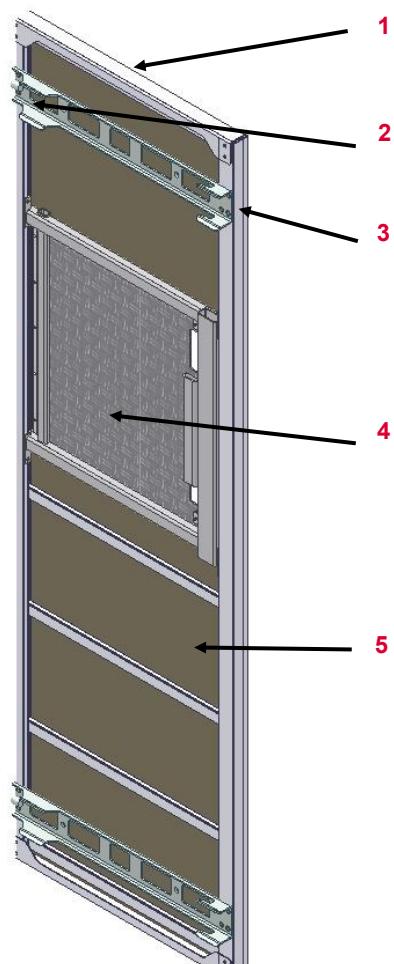



















Podlaha MXK











Č.	Popis	Číslo výrobku
1	Čelní profil	127007
2	Vodící kolík	126751
3	„Krycí kolejnice“	126745
4	Poklop	128720
5	Podlaha	









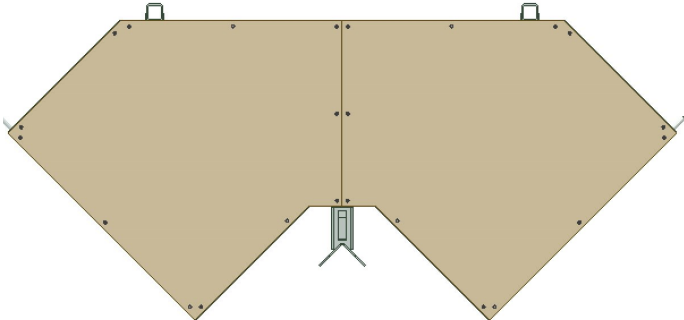

Platné pro:	Číslo výrobku
Plošina MXK 240 s otvorem	128740
Plošina MXK (Ocel) s otvorem	128812
Plošina MXK 240	126463
Plošina MXK 120	125693
Plošina MXK 90	126927
Plošina MXK (Ocel)	128310
Plošina MXK (Ocel)	128311
Plošina MXK (Ocel)	128312

Podlaha MXK	Popis	Instrukce	Fakturace	Typ
	Promáčknutý profil	 		
	<ul style="list-style-type: none"> ■ < 5 mm 	 		
	<ul style="list-style-type: none"> ■ > 5 mm ■ Prasklý materiál 			
<ul style="list-style-type: none"> ■ Poškozený čelní profil 				

Podlaha MXK	Popis	Instrukce	Fakturace	Typ
	<p>26.129 Podlaha</p> <ul style="list-style-type: none"> ■ Opotřebovaná ■ Poškozená hrubým zacházením 	 	 	 
	<p>26.130 Poškozený poklop</p>			

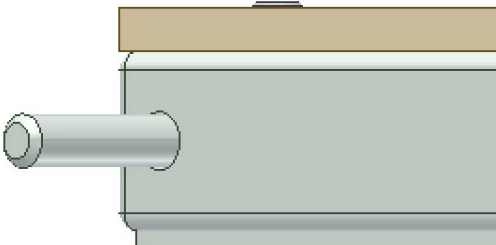
Podlaha MXK	Popis	Instrukce	Fakturace	Typ
	26.131 Ohnutý vodící kolík			
	<ul style="list-style-type: none"> ■ Je možné srovnat 			
	<ul style="list-style-type: none"> ■ Není možné srovnat 			
	<ul style="list-style-type: none"> ■ Prasklina v materiálu 			
	26.132 „Krycí kolejnice“ ohnutá			
	<ul style="list-style-type: none"> ■ Je možné srovnat 			
	<ul style="list-style-type: none"> ■ Není možné srovnat 			
	<ul style="list-style-type: none"> ■ Prasklina v materiálu 			

Podlaha MXK	Popis	Instrukce	Fakturace	Typ	
	<p>26.133 Čelní profil poškozený</p>				
	<p>26.134 Podlaha ohnutá</p>	<p>■ > 5 mm</p>			

Podlaha vnějšího rohu MXK (126545)	Popis	Instrukce	Fakturace	Typ
	Podlaha	 128761		
	■ Opotřebovaná	 128761		
	Ohnuté části	 		
	■ > 5 mm			

PERI Nájemní kritéria

MAXIMO



Podlaha MXK	Č.	Popis	Číslo výrobku
-------------	----	-------	---------------

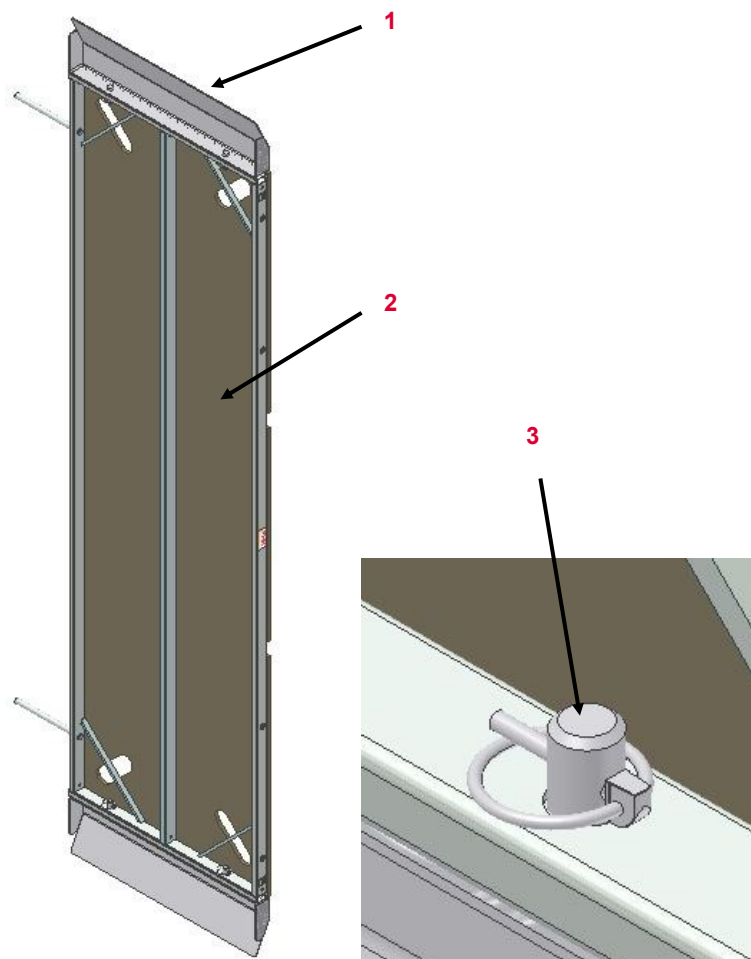

1	Přechod	128846
2	Podlaha	128856
3	Klip	127005

Podlaha MXK	Popis	Instrukce	Fakturace	Typ	
	26.135 Přejchod ohnutý				
	<ul style="list-style-type: none"> ■ Je možné srovnat 				
	<ul style="list-style-type: none"> ■ Není možné srovnat 		128846 (Přejchod) 117285 (Nýt)		
	26.136 Podlaha				
	<ul style="list-style-type: none"> ■ Opatřebovaná 				
	<ul style="list-style-type: none"> ■ Poškozená hrubým zacházením 				
	26.137 Klip				
	<ul style="list-style-type: none"> ■ Chybějící 		127005		
	<ul style="list-style-type: none"> ■ Poškozený 		127005		

PERI Nájemní kritéria







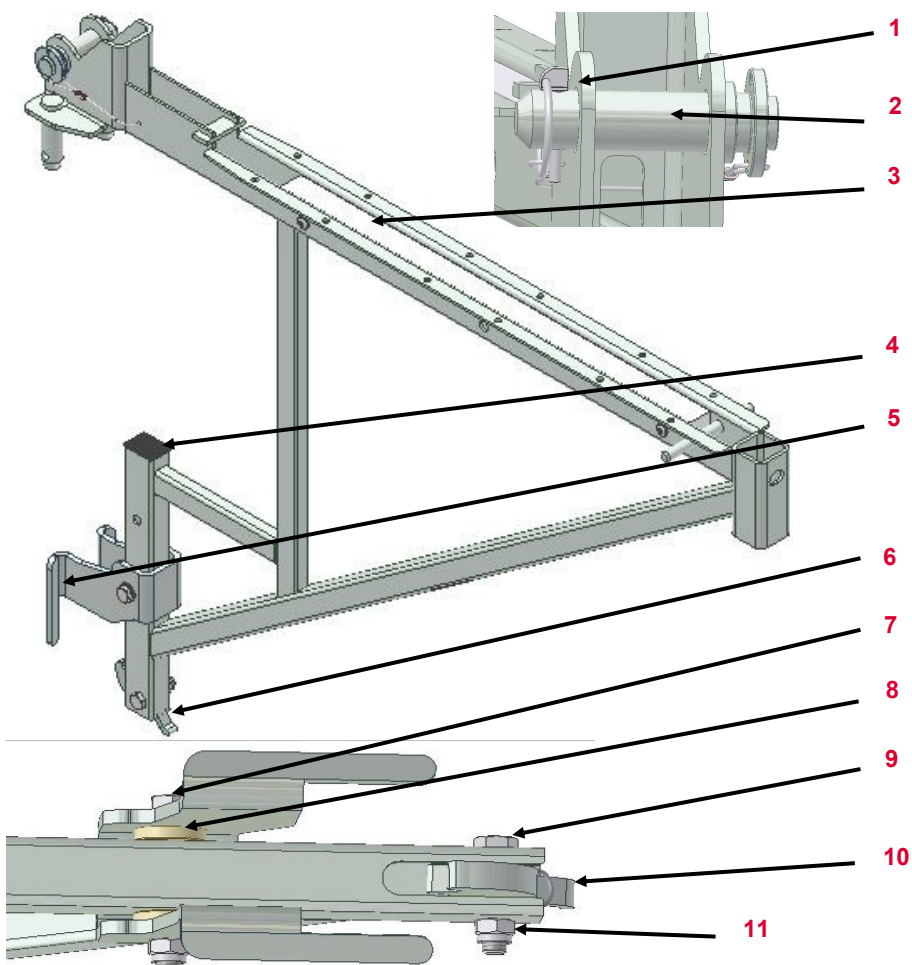







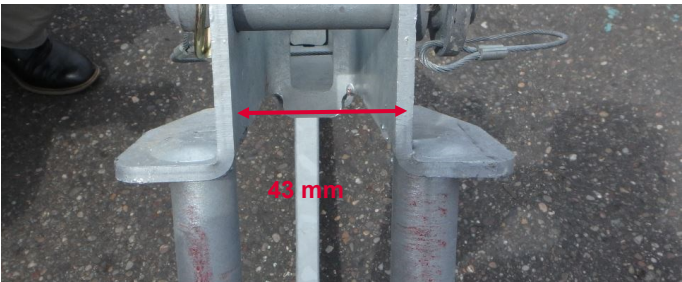

MAXIMO



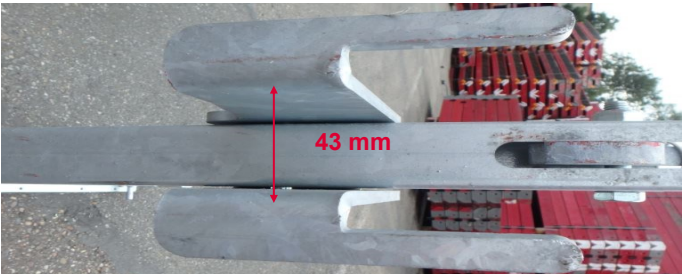











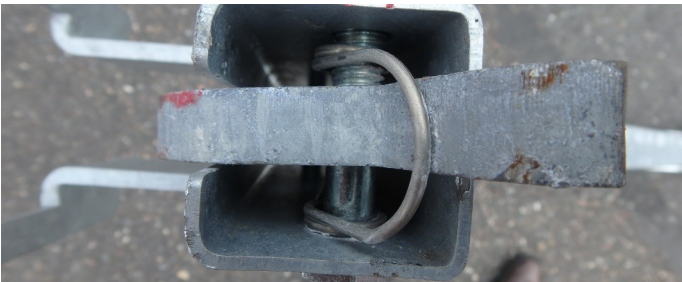





Konzola MXK	Č.	Popis	Číslo výrobku
-------------	----	-------	---------------



1	Klip	127005
2	Bezpečnostní šroub	126730
3	Plastová lišta MXK 580	126819
4	Krytka	128592
5	Připojovací hlava spodní	126728
6	Háček	126732
7	Šroub M 10x70	128356
8	Pouzdro	128621
9	Šroub M 10x45	104692
10	Pružina	127004
11	Matice M 10	780356

Konzola MXK	Popis	Instrukce	Fakturace	Typ		
	26.138 Opatřebovaná plastová lišta	 126819				
	26.139 Ohnutá připojovací hlava horní					
	<ul style="list-style-type: none"> ■ > 43.5 mm 					
	26.140 Ohnutá připojovací hlava spodní					
	<ul style="list-style-type: none"> ■ > 43.5 mm 					

Konzola MXK	Popis	Instrukce	Fakturace	Typ
	26.141 Zničený háček	 126732		
	26.142 Pružina	 127004		
	<ul style="list-style-type: none"> ■ Prasknutá 	 127004		
	26.143 Lanko	 127303		
	<ul style="list-style-type: none"> ■ Chybějící 	 127303		

PERI Nájemní kritéria

MAXIMO



Konzola MXK-RS (126540)

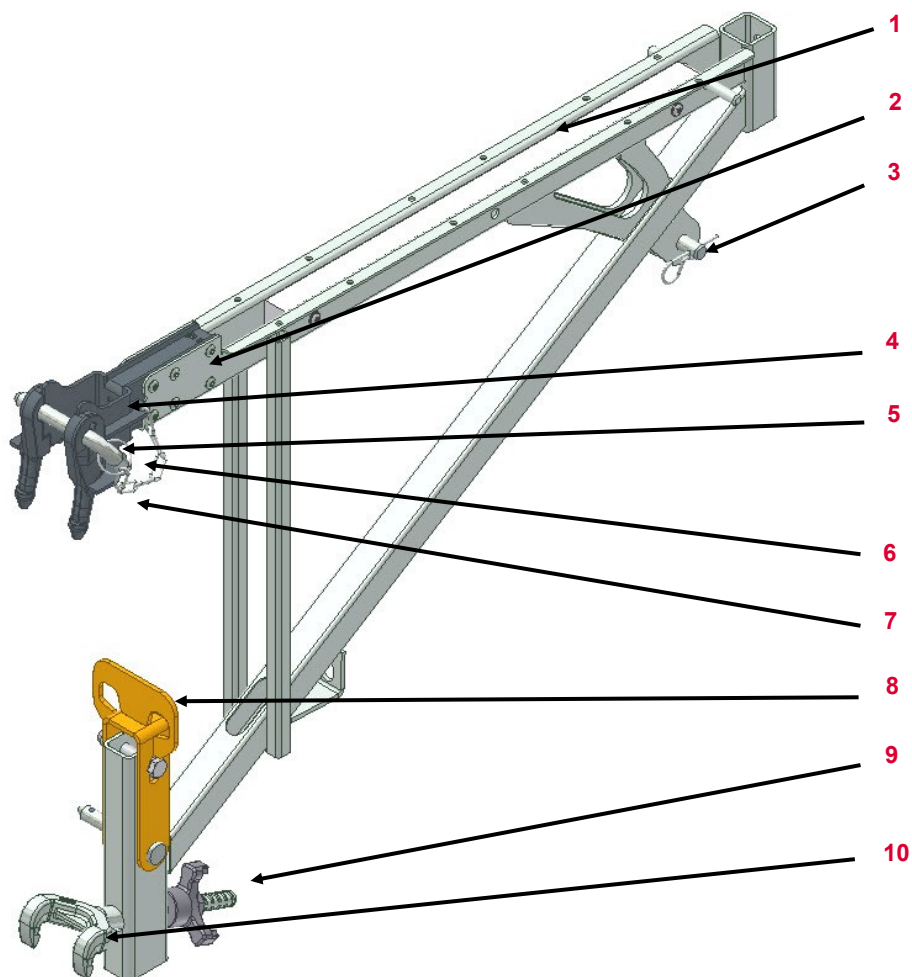













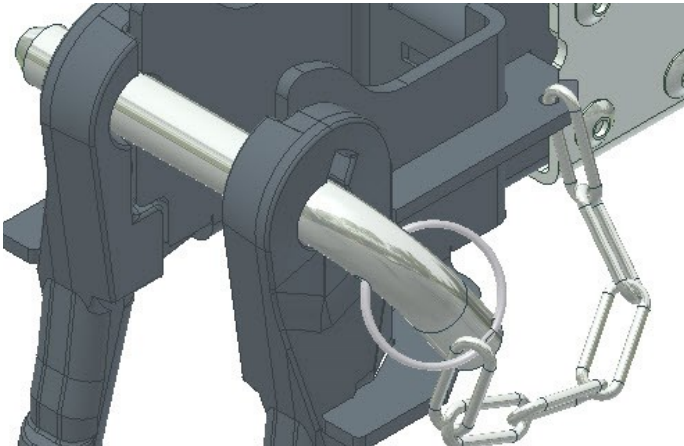









Č.	Popis	Číslo výrobku
1	Plastová lišta MXK 580	127005
2	Nýt 6,5x12,5	130151
3	Čep 16x42	027170
4	Připojení	130280
5	Čep D 16	127406
6	Kolečko k řetězu	710929
7	Řetízek	724152
8	Pouzdro	127411
9	Trojkrídlá matice DW 15	030190
10	Dvojitě háky MAR/3	124936

PERI Nájemní kritéria

















MAXIMO



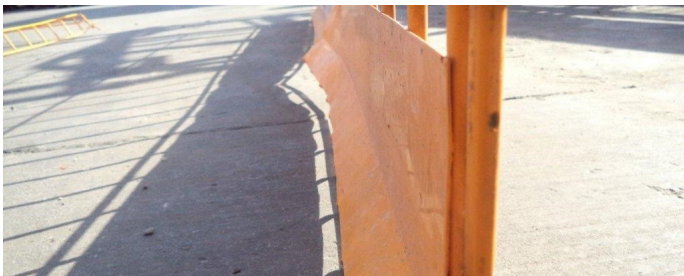













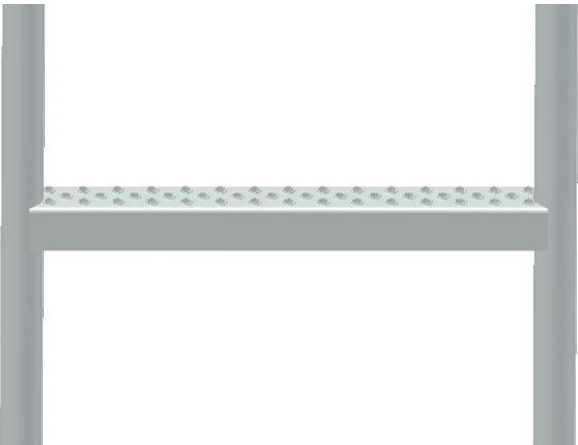







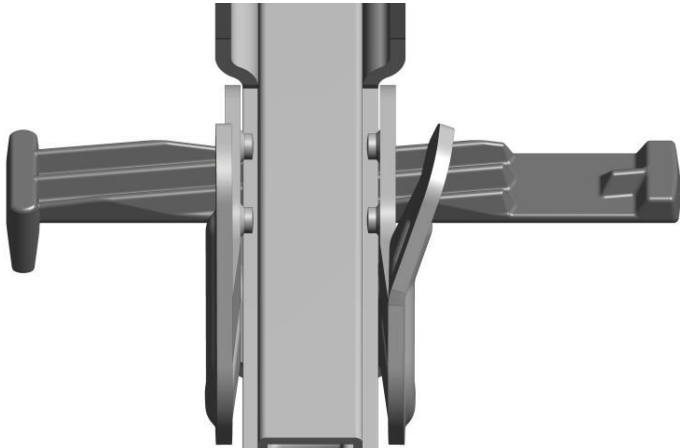

Konzola MXK– RS (126540)	Popis	Instrukce	Fakturace	Typ
	Ohnuté připojení	 Připojení	 089370	
	Chybějící části		 088178 088192	

Čelní zábradlí MXK	Popis	Instrukce	Fakturace	Typ
	26.144 Klín	<ul style="list-style-type: none"> ■ Chybějící  		
	<ul style="list-style-type: none"> ■ Ohnutý (s prasklinou v materiálu) 			
	26.145 Ohnutá okopová zarážka			
	26.146 Objímky stlačené ohnuté			

Sloupek MXK	Popis	Instrukce	Fakturace	Typ
	26.147 Ohnutý <ul style="list-style-type: none"> ■ > 10 mm 			
	26.148 Držák <ul style="list-style-type: none"> ■ Chybějící 			
	<ul style="list-style-type: none"> ■ Poškozený hrubým zacházením 			
	26.149 Bezpečnostní háček <ul style="list-style-type: none"> ■ Chybějící 	<p>710418 (bezp. háček) 710420 (pružina) 724567 (nýt)</p>		
	<ul style="list-style-type: none"> ■ Poškozený hrubým zacházením 	<p>710418 (bezp. háček) 710420 (pružina) 724567 (nýt)</p>		

Ochranná mříž PMB	Popis	Instrukce	Fakturace	Typ
	26.150 Poškozená mříž		 088072	
	26.151 Pletivo			
	<ul style="list-style-type: none"> ■ Ohnuté > 15 mm ■ vyosené 	 	 	 
	26.152 „Okopový plech“ ohnutý			
	<ul style="list-style-type: none"> ■ Je možné narovnění ■ nemožné narovnění 	 	 088244 	 









Žebřík	Popis	Instrukce	Fakturace	Typ
	26.153 Skládací západka	<ul style="list-style-type: none">  	<ul style="list-style-type: none">  	<ul style="list-style-type: none"> 
	<ul style="list-style-type: none"> ■ Chybějící 	123480	088007	
	<ul style="list-style-type: none"> ■ Poškozený hrubým zacházením 	<ul style="list-style-type: none">  	<ul style="list-style-type: none">  	<ul style="list-style-type: none"> 
	123480	088007		
	26.154 Nášlap ohnutý	<ul style="list-style-type: none">  	<ul style="list-style-type: none">  	<ul style="list-style-type: none"> 
	<ul style="list-style-type: none"> ■ Je možné narovnění 	<ul style="list-style-type: none">  	<ul style="list-style-type: none">  	<ul style="list-style-type: none"> 
	<ul style="list-style-type: none"> ■ Není možné narovnění 	<ul style="list-style-type: none">  	<ul style="list-style-type: none">  	<ul style="list-style-type: none"> 
<ul style="list-style-type: none"> ■ Poškozený svár 				

Zámek BFD MX VS	Popis	Instrukce	Fakturace	Typ
	Ohnuté čelisti		 088244	
	Rozpadlý zámek			

PERI Nájemní kritéria

Vysvětlivky znaků



Znak	Význam	Znak	Význam	Znak	Význam
	Není v pořádku – materiál je poškozený		Fakturuje se zákazníkovi		Optické poškození
	OK – materiál zůstává v nájemním skladu		Nefakturuje se zákazníkovi		Funkční poškození
	Poškozený materiál – není dovoleno vydávat materiál z bezpečnostních důvodů		Zkrácení prvku		Funkční poškození — není dovoleno vydávat materiál z bezpečnostních důvodů
	Oprava dle instrukcí		Označení prvku barvou		Statické poškození — není dovoleno vydávat materiál z bezpečnostních důvodů
	Oprava za studena — poté kontrola svárů a sousedních dílů		Výměna poškozeného dílu		
	Oprava po výpočtu hospodárnosti		Doplnění chybějícího dílu		
	Očištění materiálu				