

PERI Nájemní kritéria

DUO



Kontakt

PERI, spol. s r.o.
bednění lešení služby

Průmyslová 392
252 42 Jesenice u Prahy
tel.: 222 359 311
info@peri.cz
www.peri.cz

| Obsah | Strana | Poslední změny | Datum Iniciály | Strana |
|---------------|--------|-----------------------|------------------|--------|
| Bednicí deska | 2 | Nová verze | 08/2015 rf | |
| Rám | 16 | Vložené čísla artiklů | 02/2016 fw | 3;24 |
| Příslušenství | 24 | Další úpravy | 08/2017 | |
| Vysvětlivky | 41 | | | |
| | | | | |
| | | | | |
| | | | | |
| | | | | |
| | | | | |

PERI Nájemní kritéria

DUO



| DUO Panel | Č. | Popis | Číslo výrobku |
|-----------|----|-------|---------------|
|-----------|----|-------|---------------|

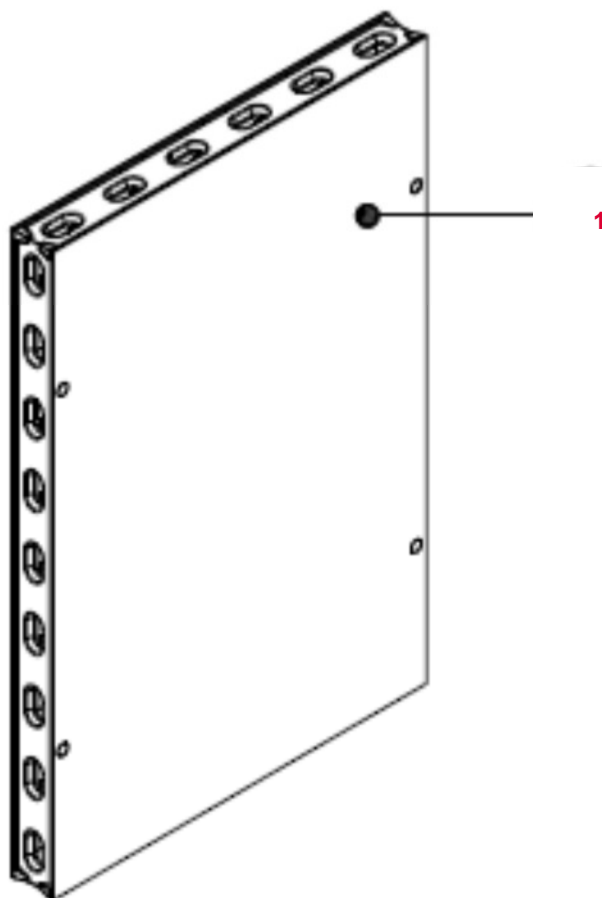

| | | |
|----------|------------|---------------|
| 1 | Panel | Bednicí deska |
| | DP 135x90 | 128228 |
| | DMP 135x75 | 128229 |
| | DP 135x60 | 128230 |
| | DMP 135x45 | 128231 |
| | DP 135x30 | 128232 |
| | DP 135x15 | 128233 |

| Platné pro | Číslo výrobku |
|--------------------|---------------|
| Panel DP 135 x 90 | 128280 |
| Panel DMP 135 x 75 | 128281 |
| Panel DP 135 x 60 | 128282 |
| Panel DMP 135 x 45 | 128283 |
| Panel DP 135 x 30 | 128284 |
| Panel DP 135 x 15 | 128285 |

PERI Nájemní kritéria DUO











| Výrobek | Číslo výrobku |
|--------------------|---------------|
| Panel DP 135 x 90 | 128280 |
| Panel DMP 135 x 75 | 128281 |
| Panel DP 135 x 60 | 128282 |
| Panel DMP 135 x 45 | 128283 |
| Panel DP 135 x 30 | 128284 |
| Panel DP 135 x 15 | 128285 |
| Panel DP 60x90 | 129837 |
| Panel DMP 60 x 75 | 129838 |
| Panel DP 60 x 60 | 129839 |
| Panel DMP 60 x 45 | 129840 |
| Panel DP 60 x 30 | 129841 |
| Panel DP 60 x 15 | 129842 |
| | |
| | |
| | |

| Výrobek | Číslo výrobku |
|---------|---------------|
| | |
| | |
| | |
| | |
| | |
| | |
| | |
| | |
| | |
| | |
| | |
| | |
| | |
| | |









PERI Nájemní kritéria DUO



| Bednicí deska | Popis | Instrukce | Fakturace | Typ |
|--|---|--|---|--|
|  | 29.01 Lehce znečištěno |  |  |  |
|  | 29.02 Extrémní znečištění (nepoužití PERI Cleanu) |  |  088974 |  |











PERI Nájemní kritéria DUO

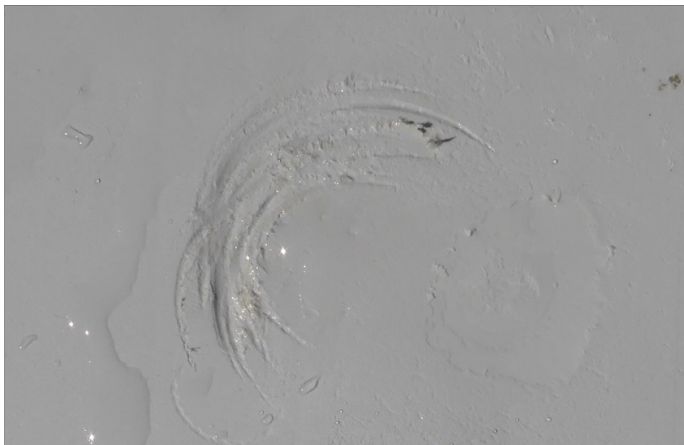

| Bednicí deska | Popis | Instrukce | Fakturace | Typ |
|--|--|--|---|--|
|  | 29.03 Zabetonovaný kotevní otvor |  |  |  |
|  | 29.04 Použití nevyhovujícího separátoru (Diesel, etc.) |  |  (str. 23) |  |

PERI Nájemní kritéria DUO



| Bednicí deska | Popis | Instrukce | Fakturace | Typ |
|--|---|---|---|---|
|  | <p>29.05 Poškození zátky v panelu DMP</p> |  |  |  |
|  | <p>29.06 Zářezy v desce panelu</p> |  |  |  |
| | <ul style="list-style-type: none"> ■ hloubka ≤ 1 mm |  |  |  |
| | <ul style="list-style-type: none"> ■ hloubka > 1 mm | | | |











PERI Nájemní kritéria DUO



| Bednicí deska | Popis | Instrukce | Fakturace | Typ | |
|---------------|--|--|---------------|--------|-----------|
| | 29.07 Poškození od vibrátoru | <ul style="list-style-type: none"> ■ ≤ 1 mm hloubky | | | |
| | <ul style="list-style-type: none"> ■ > 1 mm hloubky (možné svařit) | | | 089073 | |
| | <ul style="list-style-type: none"> ■ > 1 mm hloubky (nelze svařit) | | Bednicí deska | | (str. 23) |
| | 29.08 Poškození způsobené kladivem | <ul style="list-style-type: none"> ■ ≤ 1 mm hloubky | | | |
| | <ul style="list-style-type: none"> ■ > 1 mm hloubky | | Bednicí deska | | (str. 23) |

PERI Nájemní kritéria DUO



| Bednicí deska | Popis | Instrukce | Fakturace | Typ |
|--|--|---|---|---|
|  | 29.09 Povrchní škrábance |  |  |  |
| | <ul style="list-style-type: none"> ■ ≤ 1 mm hloubky | | | |
|  | 29.10 Hluboké škrábance |  |  |  |
| | <ul style="list-style-type: none"> ■ > 1 mm hloubky (možné svařit) | | 089073 | |
| | <ul style="list-style-type: none"> ■ > 1 mm hloubky (nelze svařit) |  |  |  |
| | | Bednicí deska | (str. 23) | |

PERI Nájemní kritéria DUO



| Bednicí deska | Popis | Instrukce | Fakturace | Typ |
|---------------|-------|-----------|-----------|-----|
|---------------|-------|-----------|-----------|-----|



29.11 Boule způsobené nárazy z rubové strany (viditelné na desce)

- $\varnothing \leq 3$ cm
- Or $\varnothing > 3$ cm



Zahřejte desku a opravte místo



Bednicí deska













(str. 23)













PERI Nájemní kritéria DUO



| Bednicí deska | Popis | Instrukce | Fakturace | Typ |
|--|---|---|---|---|
|  | 29.12 Prasknutá deska <ul style="list-style-type: none"> ■ ≤ 10cm délky |  |  089073 |  |
|  | 29.13 Prasknutá deska <ul style="list-style-type: none"> ■ > 10 cm délky a oprava možná ■ > 10 cm délky a oprava není možná |  |  089073 |  |
| | |  |  (str. 23) |  |















PERI Nájemní kritéria DUO

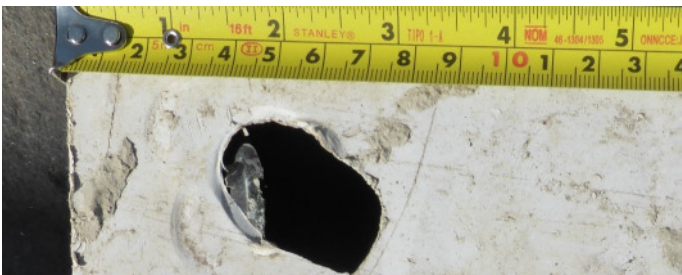

| Bednicí deska | Popis | Instrukce | Fakturace | Typ |
|--|---|--|--|---|
|  | <p>29.14 Lehké odřenyiny hrany desky</p> <ul style="list-style-type: none"> ■ ≤ 5 mm šířky | <p> Srovnání hrany škrabkou</p> |  |  |
|  | <p>29.15 Velké odřenyiny hrany desky</p> <ul style="list-style-type: none"> ■ > 5 mm šířky a oprava možná ■ Oprava není možná | <p></p> | <p> 089073</p> |  |
| | | <p></p> | <p> (str. 23)</p> |  |

PERI Nájemní kritéria DUO



| Bednicí deska | Popis | Instrukce | Fakturace | Typ |
|---|--|---|---|---|
|  | 29.16 Díra v desce <ul style="list-style-type: none"> ■ ≤ Ø 5 mm |  |  |  |
|  | 29.17 Malá díra <ul style="list-style-type: none"> ■ ≤ 1 cm a oprava možná ■ Oprava není možná |  |  089073 |  |
|  | 29.18 Velká díra <ul style="list-style-type: none"> ■ > 1 cm a oprava možná ■ Oprava není možná |  |  089073 |  |
| | |  |  (str. 23) |  |

PERI Nájemní kritéria DUO



| Bednicí deska | Popis | Instrukce | Fakturace | Typ | |
|---------------|---|---|---------------|--------|-----------|
| | 29.19 Zářez na hraně desky | <ul style="list-style-type: none"> ■ ≤ 1 cm délky a ≤ 1 mm hloubky | | | |
| | <ul style="list-style-type: none"> ■ > 1 cm délky a > 1 mm hloubky | | | 089073 | |
| | 29.21 Zcela stržená hrana desky | <ul style="list-style-type: none"> ■ ≤ 1 cm délky a ≤ 1 mm hloubky | | 089073 | |
| | <ul style="list-style-type: none"> ■ > 1 cm délky a > 1 mm hloubky | | Bednicí deska | | (str. 23) |









PERI Nájemní kritéria DUO

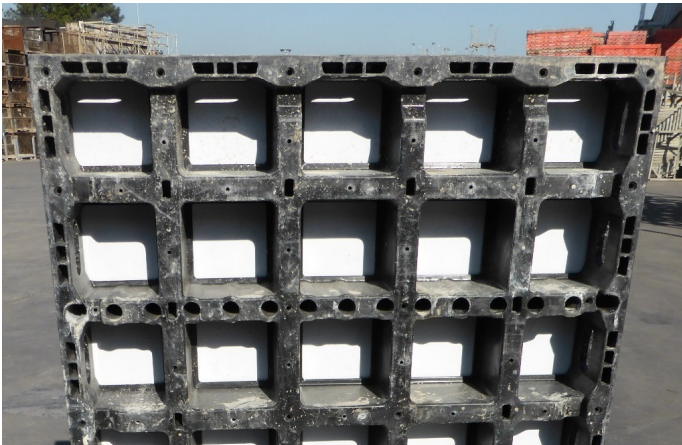

| Bednicí deska | Popis | Instrukce | Fakturace | Typ |
|---------------|------------------------------------|---------------|-----------|-----|
| | 29.22 Odřená hrana desky | | | |
| | ■ ≤ 5 mm délky | ✓ | | |
| | ■ > 5 mm délky | | | |
| | | | 089073 | |
| | 29.23 Nadzvednutý roh desky | | | |
| | ■ ≤ 2 cm délky | | | |
| | ■ > 2 cm délky | | | |
| | | Bednicí deska | (str. 23) | |

PERI Nájemní kritéria DUO



| Bednicí deska | Popis | Instrukce | Fakturace | Typ |
|--|---|---|--|--|
|  | 29.24 Chybějící vruty |  |  |  |
|  | 29.25 Znečištění betonem z důvodu chybějícího vrutu |   |  |  |

PERI Nájemní kritéria

DUO



| DUO Panel | Č. | Popis | Číslo výrobku |
|-----------|----|-------|---------------|
|-----------|----|-------|---------------|

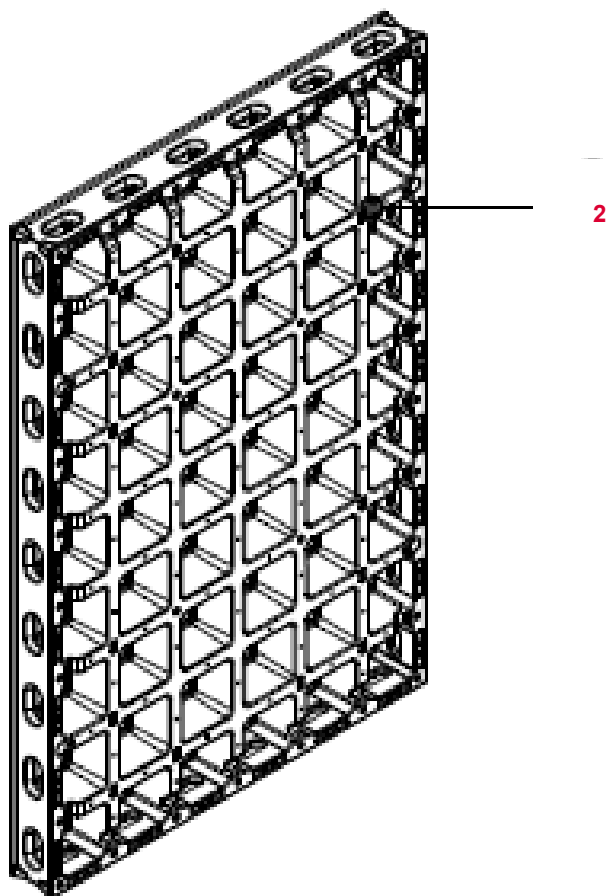

















| | | |
|----------|------------|--------|
| 2 | Panel | Rám |
| | DP 135x90 | 128222 |
| | DMP 135x75 | 128223 |
| | DP 135x60 | 128224 |
| | DMP 135x45 | 128225 |
| | DP 135x30 | 128226 |
| | DP 135x15 | 128227 |

| Platné pro | Číslo výrobku |
|--------------------|---------------|
| Panel DP 135 x 90 | 128280 |
| Panel DMP 135 x 75 | 128281 |
| Panel DP 135 x 60 | 128282 |
| Panel DMP 135 x 45 | 128283 |
| Panel DP 135 x 30 | 128284 |
| Panel DP 135 x 15 | 128285 |















PERI Nájemní kritéria DUO



| Rám | Popis | Instrukce | Fakturace | Typ |
|---|--|--|--|---|
|  | 29.26 Rám znečištěný betonem |  Vysokotlaké čištění vodou |  089074 |  |
|  | 29.27 Rám znečištěný betonem |  Vysokotlaké čištění vodou nebo dlátem |  089974 |  |
|  | 29.28 Rukojeť rámu znečištěná betonem |  Odstraňte dlátem |  089074 |  |
|  | 29.29 Rastr rámu znečištěný betonem |  Vysokotlaké čištění vodou nebo dlátem |  089074 |  |









PERI Nájemní kritéria DUO



| Rám | Popis | Instrukce | Fakturace | Typ |
|---|---|--|--|--|
|  | 29.30 Poškozená hrana rámu | | | |
| | <ul style="list-style-type: none"> ■ ≤ 5 mm hloubky ■ > 5 mm hloubky | <ul style="list-style-type: none">   Rám | <ul style="list-style-type: none">   (str. 23) | <ul style="list-style-type: none">   |
|  | 29.31 Poškozený roh rámu | | | |
| | <ul style="list-style-type: none"> ■ ≤ 1 cm hloubky ■ > 1 cm hloubky | <ul style="list-style-type: none">   Rám | <ul style="list-style-type: none">   (str. 23) | <ul style="list-style-type: none">   |

PERI Nájemní kritéria DUO















| Rám | Popis | Instrukce | Fakturace | Typ |
|--|------------------------|--|--|--|
|  | 29.32 PPrasknuté žebro |  Rám |  (str. 23) |  |
|  | 29.33 Vytržené žebro |  Rám |  (str. 23) |  |

PERI Nájemní kritéria















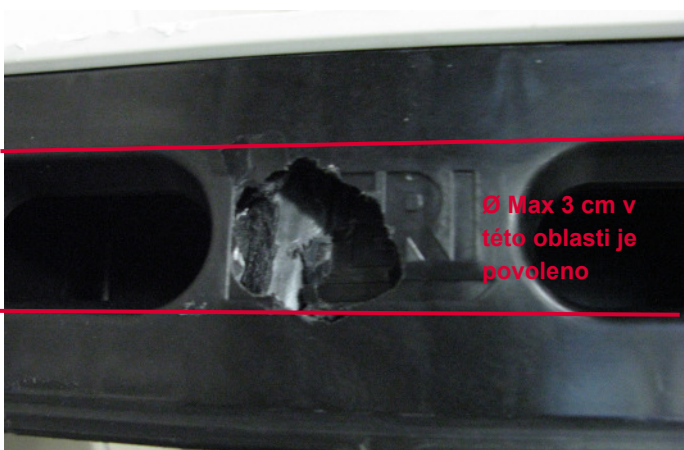

DUO



| Rám | Popis | Instrukce | Fakturace | Typ |
|---|---|---|---|---|
|  | 29.34 Řez na spodní straně rámu |  Rám |  (str. 23) |  |
|  | 29.35 Řez na boční straně rámu (včetně bednicí desky) |  Rám |  (str. 23) |  |
|  | 29.36 Vytržená spodní strana žebra |  Rám |  (str. 23) |  |











PERI Nájemní kritéria DUO



| Rám | Popis | Instrukce | Fakturace | Typ |
|---|---|---|---|---|
|  | 29.37 Díra po hřebíku nebo vyvrtaná díra <ul style="list-style-type: none"> ■ ≤ Ø 5 mm |  |  |  |
| | <ul style="list-style-type: none"> ■ > Ø 5 mm (mimo označenou oblast, obrázek dole) |  Rám |  (str. 23) |  |
|  <p>Ø Max 3 cm v této oblasti je povoleno</p> | 29.38 Velká díra nebo prasklina v rámu <ul style="list-style-type: none"> ■ ≤ Ø 3 cm ve značené oblasti (ve stejné výšce jako rukojeť) |  |  |  |
| | <ul style="list-style-type: none"> ■ > Ø 3 cm ve značené oblasti |  Rám |  (str. 23) |  |
| | <ul style="list-style-type: none"> ■ > Ø 5 mm mimo značenou oblast |  Rám |  (str. 23) |  |

PERI Nájemní kritéria DUO



| Rám | Popis | Instrukce | Fakturace | Typ |
|--|---------------------------------|---|--|--|
|  | 29.39 Vytržený kotevní otvor |   |  |  |
|  | 29.40 Vytržený roh profilu rámu |   |  |  |

PERI Nájemní kritéria

DUO



| Výrobek | Bednicí deska | | Rám | |
|--------------------|---------------|--------------------------|--------------|--------------------------|
| | Náhradní díl | Číslo servisního artiklu | Náhradní díl | Číslo servisního artiklu |
| Panel DP 135 x 90 | 128228 | 084407 | 128222 | 089066 |
| Panel DMP 135 x 75 | 128229 | 084408 | 128223 | 089067 |
| Panel DP 135 x 60 | 128230 | 084409 | 128224 | 089068 |
| Panel DMP 135 x 45 | 1238231 | 084410 | 128225 | 089069 |
| Panel DP 135 x 30 | 128232 | 084411 | 128226 | 089070 |
| Panel DP 135 x 15 | 128233 | 084412 | 128227 | 089071 |

PERI Nájemní kritéria DUO



| Vložka | Č. | Popis | Číslo výrobku |
|--------|----|-------|---------------|
|--------|----|-------|---------------|

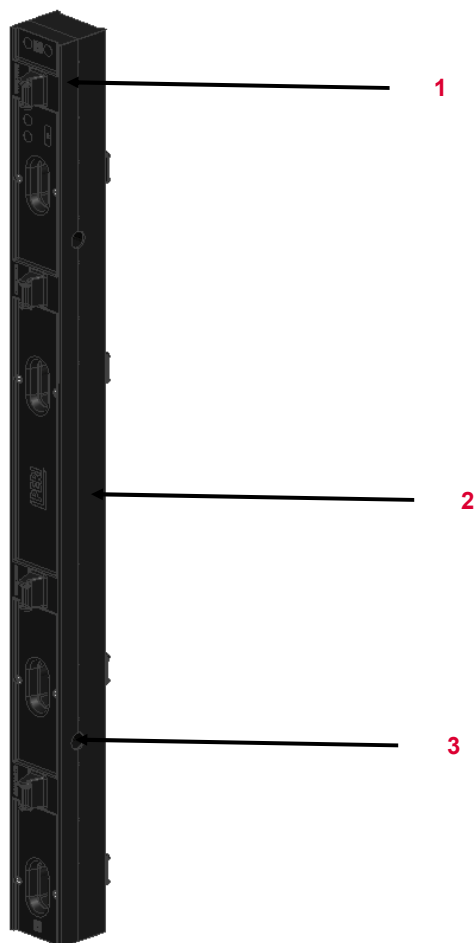













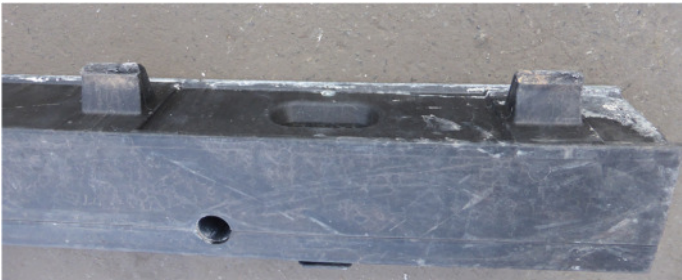

- | | |
|---|-------------------|
| 1 | Profil vložky DWC |
| 2 | Profil vložky DWC |
| 3 | Kotevní otvor |

| Platné pro | Číslo výrobku |
|-------------------|---------------|
| Vložka DWC 135x10 | 128292 |
| Vložka DWC 135x9 | 128291 |
| Vložka DWC 135x8 | 128290 |
| Vložka DWC 135x7 | 128289 |
| Vložka DWC 135x6 | 128288 |
| Vložka DWC 135x5 | 128287 |
| Vložka DWC 60x5 | 129879 |
| Vložka DWC 60x6 | 129880 |
| Vložka DWC 60x7 | 129881 |
| Vložka DWC 60x8 | 129883 |
| Vložka DWC 60x9 | 129883 |
| Vložka DWC 60x10 | 129884 |

PERI Nájemní kritéria









DUO



| Vložka | Popis | Instrukce | Fakturace | Typ |
|---|------------------------------|---|---|---|
|  | 29.41 Vytržený kotevní otvor |   |  |  |
|  | 29.42 Utržený zub |   |  |  |
|  | 29.43 Díry |   |  |  |

PERI Nájemní kritéria DUO



| Klip DUO (128247) | Popis | Instrukce | Fakturace | Typ |
|--|--------------------------|--|--|--|
|  | 29.44 Zlomená rukojeť |  |  |  |
|  | 29.69 Znečistěno betonem |  |  |  |

PERI Nájemní kritéria

DUO



| Držák lešenářské trubky (128293) | Popis | Instrukce | Fakturace | Typ |
|----------------------------------|-------|-----------|-----------|-----|
|----------------------------------|-------|-----------|-----------|-----|



29.45 Utržená čelist











29.70 Znečištěno betonem



PERI Nájemní kritéria

DUO



| Úchyt pro stabilizátor (128294) | Popis | Instrukce | Fakturace | Typ |
|--|----------------------|---|---|--|
|  | 29.46 Zlomené oko |   |  |  |
|  | 29.47 Zlomená matice |  128254 |  089072 |  |

PERI Nájemní kritéria

DUO



Úchyt pro jeřáb (128296)

Popis

Instrukce

Fakturace

Typ











29.48 Utržené části nebo nefukční
(obrázek neukazuje poškození)

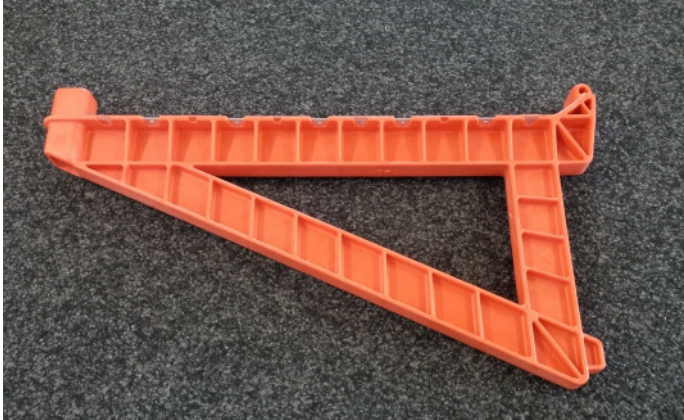

PERI Nájemní kritéria

DUO



| Konzola DUO (128257) | Popis | Instrukce | Fakturace | Typ |
|---|--|---|--|--|
|  | 29.49 1. testovací verze vyrobená z plastu (material musí být vyříděn a vyměněn za 2. verzi) |   |  |  |
|  | 29.50 2. verze plast + ocel |  |  |  |

PERI Nájemní kritéria DUO



| Konzola DUO (128257) | Popis | Instrukce | Fakturace | Typ |
|----------------------|-------|-----------|-----------|-----|
|----------------------|-------|-----------|-----------|-----|



29.71 Zlomení



29.72 Znečištění betonem



PERI Nájemní kritéria

DUO



| Vyrovnávací závora (128255) | Popis | Instrukce | Fakturace | Typ |
|-----------------------------|-------|-----------|-----------|-----|
|-----------------------------|-------|-----------|-----------|-----|



29.51 Prasklina uprostřed



29.73 Zlomení



PERI Nájemní kritéria DUO



| Podpory pro nastavení (129809; 129811) | Popis | Instrukce | Fakturace | Typ |
|--|-------|-----------|-----------|-----|
|--|-------|-----------|-----------|-----|



29.52 Vyrhnutá část

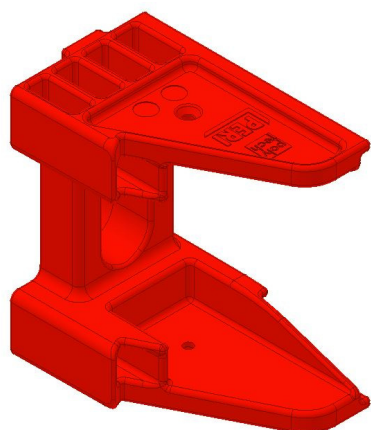















29.53 Prasklina v materiálu

- > 3 mm hloubka



PERI Nájemní kritéria DUO











| Spínací kotva DUO (128256) | Popis | Instrukce | Fakturace | Typ |
|--|--|--|--|--|
|  | <p>29.54 Závít</p> <ul style="list-style-type: none"> ■ Nepoužitelný ■ Poškozený hrubou silou | <div style="display: flex; flex-direction: column; gap: 10px;"> <div style="display: flex; gap: 5px;">   </div> <div style="display: flex; gap: 5px;">   </div> </div> | <div style="display: flex; flex-direction: column; gap: 10px;">   </div> | <div style="display: flex; flex-direction: column; gap: 10px;">   </div> |
|  | <p>29.55 Vytržená část</p> | <div style="display: flex; gap: 5px;">   </div> |  |  |

PERI Nájemní kritéria



DUO



| Roh DC (128286; 129864) | Popis | Instrukce | Fakturace | Typ |
|--|--------------------------|--|--|--|
|  | 29.56 Vytržená část |  |  |  |
|  | 29.57 Vytržená část zubu |  |  |  |

PERI Nájemní kritéria DUO



| Podpěrná hlava DFH (128298; 129862) | Popis | Instrukce | Fakturace | Typ |
|--|---|---|--|--|
|  | <p>29.58 Škrábance Praskliny</p> <ul style="list-style-type: none"> ■ ≤ 5 mm hloubka ■ > 5 mm hloubka | <ul style="list-style-type: none"> ✓ 🗑️ 🚫 | <ul style="list-style-type: none"> 🚫 📦 | <ul style="list-style-type: none"> 👁️ 📦 kg |
|  | <p>29.59 Vytržená část Díry</p> | <ul style="list-style-type: none"> 🗑️ 🚫 | <ul style="list-style-type: none"> 📦 | <ul style="list-style-type: none"> 📦 kg |

PERI Nájemní kritéria DUO



| Podpěrná hlava DFH (128298; 129862) | Popis | Instrukce | Fakturace | Typ |
|-------------------------------------|-------|-----------|-----------|-----|
|-------------------------------------|-------|-----------|-----------|-----|

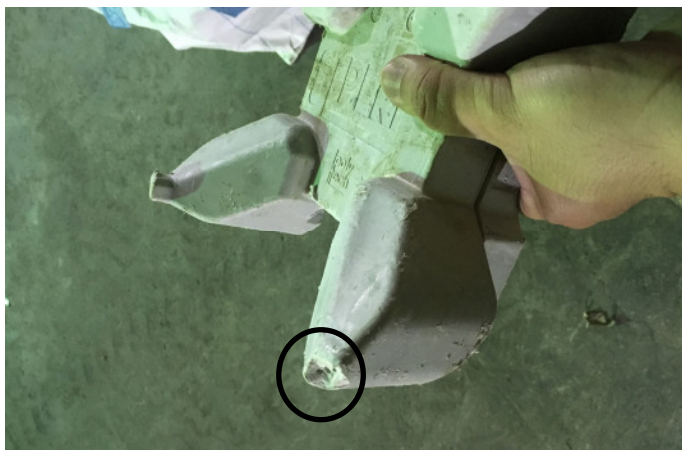

29.60 Zlomený nos



29.61 Opatřebovaný nos

■ šíře < 5 mm



PERI Nájemní kritéria DUO



| Držák sloupku zábradlí (128297) | Popis | Instrukce | Fakturace | Typ |
|---------------------------------|-------|-----------|-----------|-----|
|---------------------------------|-------|-----------|-----------|-----|



29.63 Utržená část



29.64 Prasklina v materiálu













- > 3 mm hloubka

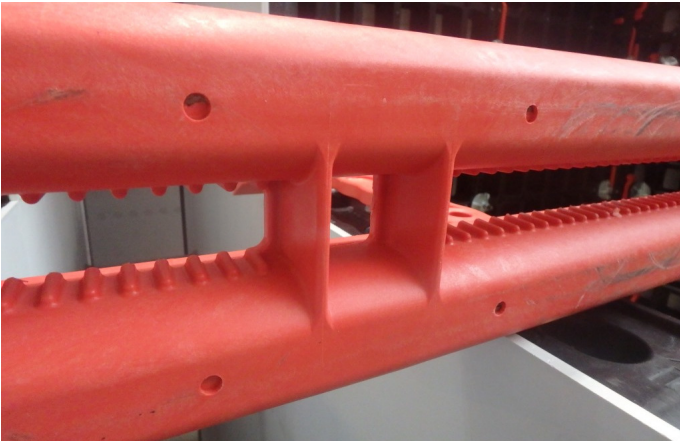

PERI Nájemní kritéria

DUO



| Stěnový držák DUO 82 (128263) | Popis | Instrukce | Fakturace | Typ |
|--|--|--|--|--|
|  | <p>29.65 Zuby</p> <ul style="list-style-type: none"> ■ Opatřebované (spojovací tyč proklouzne) ■ Odlovení | <div style="display: flex; justify-content: space-around;"> <div style="text-align: center;">   </div> <div style="text-align: center;">   </div> </div> | <div style="display: flex; justify-content: space-around;"> <div style="text-align: center;">  </div> <div style="text-align: center;">  </div> </div> | <div style="display: flex; justify-content: space-around;"> <div style="text-align: center;">  </div> <div style="text-align: center;">  </div> </div> |
|  | <p>29.66 Vylomená část</p> | <div style="text-align: center;">   </div> | <div style="text-align: center;">  </div> | <div style="text-align: center;">  </div> |

PERI Nájemní kritéria

DUO



| Držák rámu DUO (129976) | Popis | Instrukce | Fakturace | Typ |
|-------------------------|-------|-----------|-----------|-----|
|-------------------------|-------|-----------|-----------|-----|

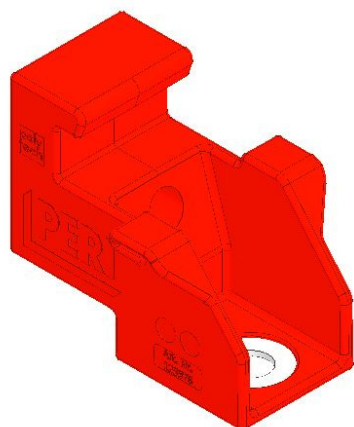

29.67 Vylomená část

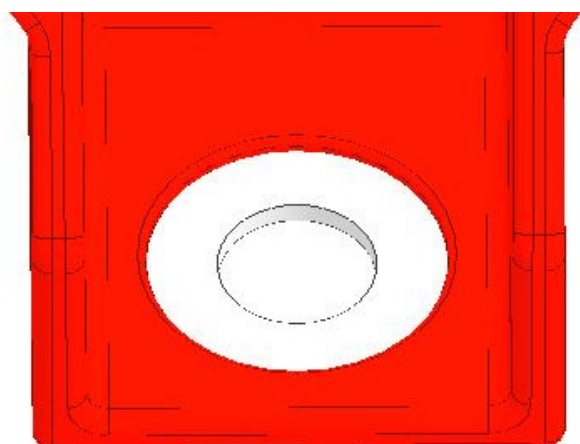

29.68 Vložka držáku rámu je prasklá| zlomená



PERI Nájemní kritéria

Vysvětlivky znaků



| Znak | Význam | Znak | Význam | Znak | Význam |
|---|--|--|----------------------------|---|--|
|  | Není v pořádku – materiál je poškozený |  | Fakturuje se zákazníkovi |  | Optické poškození |
|  | OK – materiál zůstává v nájemním skladu |  | Nefakturuje se zákazníkovi |  | Funkční poškození |
|  | Poškozený materiál – není dovoleno vydávat materiál z bezpečnostních důvodů |  | Zkrácení prvku |  | Funkční poškození — není dovoleno vydávat materiál z bezpečnostních důvodů |
|  | Oprava dle instrukcí |  | Označení prvku barvou |  | Statické poškození — není dovoleno vydávat materiál z bezpečnostních důvodů |
|  | Oprava za studena — poté kontrola svárů a sousedních dílů |  | Výměna poškozeného dílu | | |
|  | Oprava po výpočtu hospodárnosti |  | Doplnění chybějícího dílu | | |
|  | Očištění materiálu | | | | |